

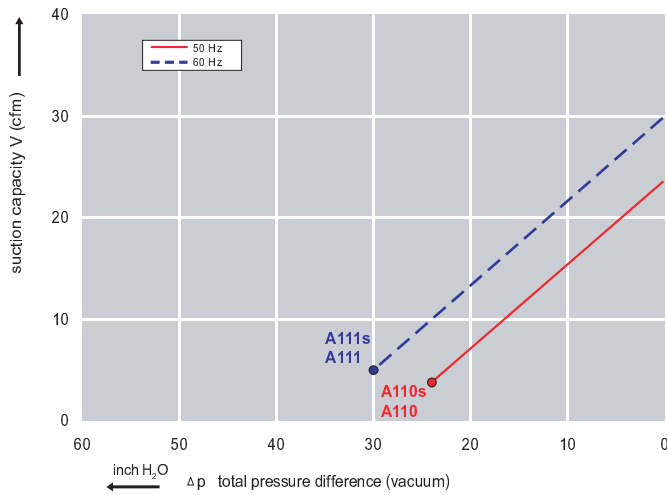

Features:

- Cooler running, outboard bearing provides maintenance-free operation
- Environmentally friendly oil-free technology
- Extremely quiet operation
- All motors are standard TEFC with Class F insulation, UL recognized, CE Compliant
Explosion-Proof motors available
- Custom construction blowers are available
- Rugged die cast aluminum construction

Performance curve for Vacuum pump



Performance curve for Compressor

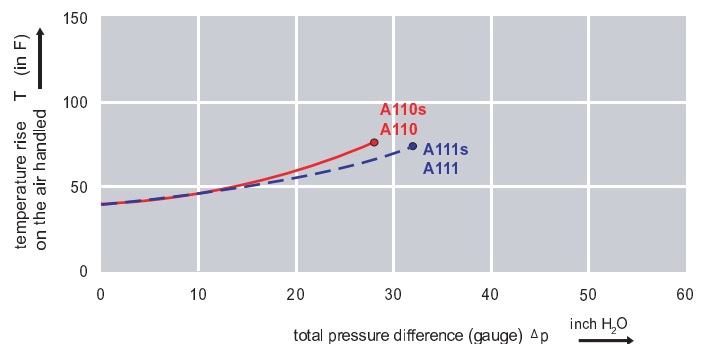
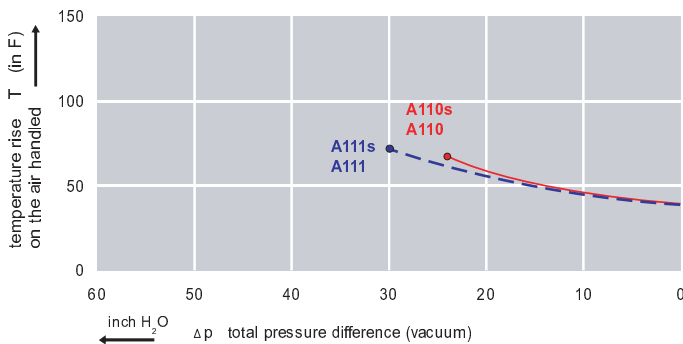
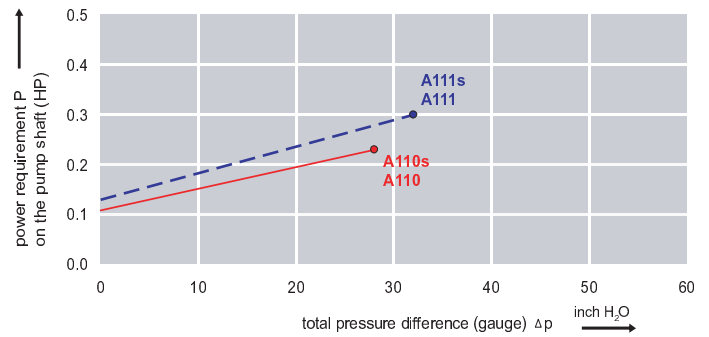
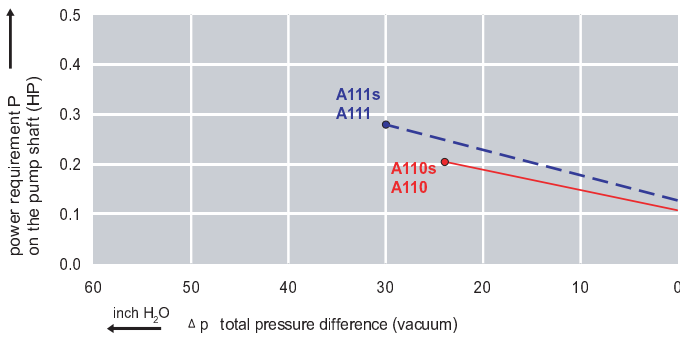
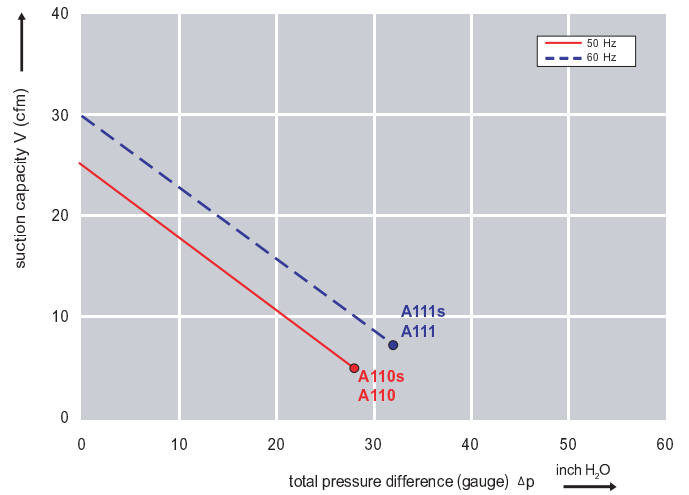

Dimensions: (inches)

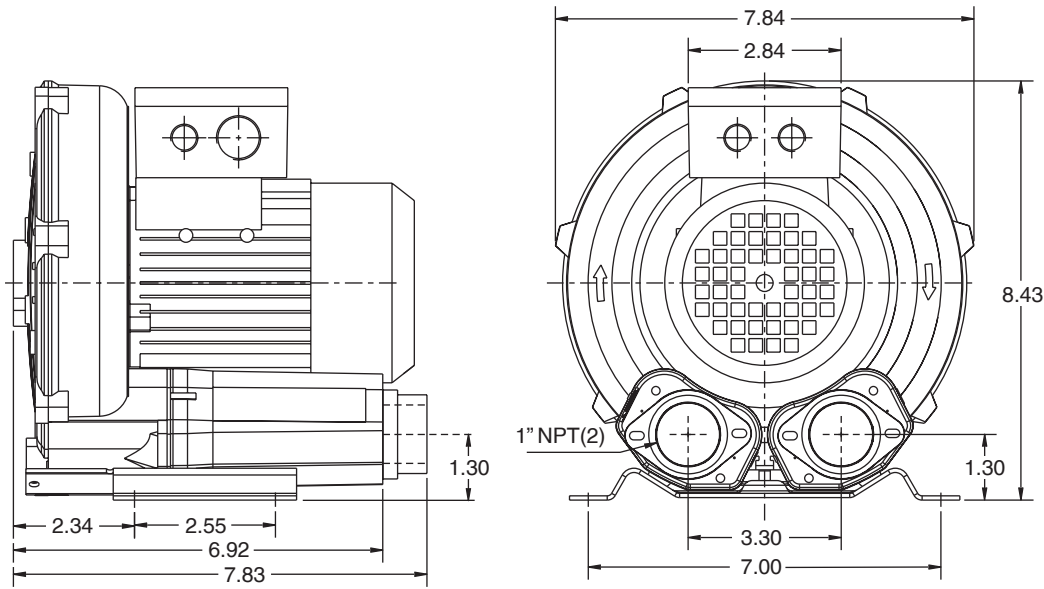

Relief valve:

VC51Z (Vacuum)
PC51Z (Pressure)

Filter:

ATF-125-1337
(Vacuum)
AFS-20-125-10
(Pressure)

Specifications subject to change without notice. Please contact factory for specification updates.

Selection & Ordering Data - Type 3BA1100

Curve No.	Order No.	Fre- quency Hz	Rated power HP	Input voltage		Input current		Permissible total differential pressure ²⁾		Sound pressure level ³⁾ dB(A)	Weight ca. lbs
				V		A		Vacuum inch H2O	Compressor inch H2O		
3~ 50/60 Hz IP55 insulation material class F											
A 110	3BA1100-7AT06	50	0.27	200D ... 240D	345Y ... 415Y	1.0D	0.6 Y	-24	28	50	13
A 111	3BA1100-7AT06	60	0.31	220D ... 250D	415Y ... 460Y	1.0D	0.6 Y	-30	32	53	13
1~ 50/60 Hz IP55 with attached capacitor for continuous operation											
A 110s	3BA1100-7AS05	50	0.27	115	230	3.0D	1.5 Y	-24	28	50	13
A 111s	3BA1100-7AS05	60	0.31	115	230	2.6D	1.3 Y	-30	32	53	13

Suitable for 208 Volt Operation

All curves are rated at 14.7 psia and 68°F ambient conditions and are reported in SCFM referenced to 68°F and 14.696 psia sea level conditions. Curve values are nominal, actual performance may vary by up to 10% of the values indicated. For inlet temperatures above approximately 80° F or for handling gases other than air, please contact your Airtech sales representative for assistance.