

# *Instruction Manual*

## iXL120 Dry Pump System





# Declaration of Conformity

We, Edwards,  
Crawley Business Quarter,  
Manor Royal,  
Crawley,  
West Sussex, RH10 9LW, UK

declare under our sole responsibility, as manufacturer and person within the EU authorised to assemble the technical file, that the product(s)

iXL120 A59141000

and accessories:

Disconnect Box 200-460 V 50-60 Hz A50806000  
EMS button D37491500

to which this declaration relates is in conformity with the following standard(s) or other normative document(s)

EN1012-2:1997	Compressors and Vacuum Pumps Safety Requirements. Part 2 - Vacuum Pumps.
EN61010-1: 2001	Safety Requirements for Electrical Equipment for Measurement, Control and Laboratory Use. Part 1 General Requirements.
EN 61326-1: 2006	Electrical Equipment for Measurement, Control and Laboratory Use - EMC Requirements. (Industrial Location Immunity - Class A Emissions)
ANSI/UL61010-1:2004 + Rev 2008	Safety Requirements for Electrical Equipment for Measurement, Control and Laboratory Use - Part 1: General Requirements.
SEMI S2-0709	Environmental, Health and Safety Guideline for Semiconductor Manufacturing Equipment.

and fulfils all the relevant provisions of

2006/42/EC	Machinery Directive
2006/95/EC	Low Voltage Directive
2004/108/EC	Electromagnetic Compatibility (EMC) Directive
2011/65/EC*	Restriction of Certain Hazardous Substances (RoHS) Directive

\* i.e. The product(s) contain less than - 0.1wt% for hexavalent chromium, lead, mercury, PBB and PBDE; 0.01wt% for cadmium - in homogeneous materials (subject to the exemptions allowed by the Directive). This information relates only to products sold on or after the date of this certificate. Edwards has taken all reasonable steps to confirm this statement, which is based mainly on information from our suppliers. Whilst the RoHS Directive does not legally apply to this vacuum equipment, we recognize that component compliance is relevant to many of our customers.

Note: This declaration covers all product serial numbers from the date this Declaration was signed onwards.



Malcolm Gray, Technical Manager - Dry Pumps

13.11.2012 Shoreham

Date and Place

This product has been manufactured under a quality system registered to ISO9001

# Contents

Section	Page
<b>1</b>	<b>Introduction</b> ..... 1
1.1	Scope and definitions ..... 1
1.2	Applications ..... 2
1.3	The iXL120 system ..... 3
1.4	Priority of control ..... 4
<b>2</b>	<b>Technical data</b> ..... 5
2.1	Technical data ..... 5
2.2	Loading ..... 6
2.3	Electrical data ..... 7
2.4	Electrical connections and cables ..... 9
2.5	Cooling water data ..... 11
2.6	Nitrogen purge system ..... 11
<b>3</b>	<b>Installation</b> ..... 13
3.1	Safety ..... 13
3.2	Removing the iXL120 system from the packaging ..... 14
3.3	Locate the iXL120 ..... 15
3.4	Connect the iXL120 system to your vacuum/exhaust system and interstage connection (if fitted) ..... 15
3.5	Leak test the iXL120 system ..... 16
3.6	Connect the nitrogen supply ..... 16
3.6.1	Flammable/pyrophoric materials ..... 16
3.6.2	Gas purges ..... 17
3.7	Connect the electrical supply to the dry pumping system ..... 17
3.7.1	Electrical connector locking mechanism ..... 20
3.8	Connect to your emergency stop circuit ..... 20
3.9	Connect to your control equipment ..... 21
3.9.1	Inputs ..... 21
3.10	Connect the cooling-water hoses ..... 22
3.11	Commission the iXL120 system ..... 22
<b>4</b>	<b>Operation</b> ..... 23
4.1	Start-up ..... 23
4.2	Status indicators ..... 24
4.3	Manual shut-down ..... 24
4.4	Automatic shut-down ..... 25
4.5	Unplanned shut down and alarms ..... 25
4.6	Emergency stop (EMS) ..... 26
4.7	Restart the pump after an emergency stop or automatic shut-down ..... 26
4.8	Auto Tune ..... 26
4.8.1	Auto Tune requirements ..... 26
4.8.2	Accessing Auto Tune ..... 26
4.8.3	Auto Tune configuration ..... 27
4.8.4	Starting the Auto Tune process ..... 27
4.8.5	Monitoring Auto Tune progress ..... 27
4.8.6	Cancelling the Auto Tune process ..... 27
4.8.7	Returning the pump to factory default speeds ..... 27
4.8.8	Important notes about Auto Tune ..... 28

<b>5</b>	<b>Maintenance</b>	<b>29</b>
5.1	Safety and maintenance frequency	29
5.2	Relocate the system for maintenance	30
5.3	Draining the cooling water	31
5.4	General maintenance	32
5.5	Inspect the connections, pipelines, cables and fittings	32
<b>6</b>	<b>Transportation, storage and disposal</b>	<b>33</b>
6.1	Transportation	33
6.2	Storage	33
6.3	Disposal	33
<b>7</b>	<b>Service, spares and accessories</b>	<b>35</b>
7.1	Introduction	35
7.2	Service	35
7.3	Accessories	35
7.3.1	Disconnect box	35
7.3.2	EMS button	36
7.3.3	Accessory modules	36
7.3.4	Pump Display Terminal (PDT)	36
7.3.5	PDT adaptor cable	36
7.3.6	PDT holster	36
7.3.7	PDT extension cable	37
7.3.8	Lifting / seismic / stacking brackets (pair)	37
7.3.9	Water flow control valve (1 lpm)	37
7.3.10	Stainless steel water fittings (pair)	37
7.3.11	Main power connector	37
7.3.12	EMS terminator plug	38
7.3.13	Interface modules	38
	<b>Appendix A1 Pump Display Terminal (PDT)</b>	<b>41</b>
A1.1	PDT	41
A1.1.1	LEDs	41
A1.1.2	Pump start / stop and control	42
A1.1.3	Warning / alarm display and acknowledgement	42
A1.1.4	Menus	43
	<b>Appendix A2 Troubleshooting</b>	<b>47</b>
A2.1	Warnings	47
A2.1.1	LED warning indicators	47
A2.1.2	PDT warnings	47
A2.2	Alarms	48
A2.2.1	LED alarm indicators	48
A2.2.2	PDT alarms	48
A2.3	Inverter warnings and alarms	49
A2.4	Other	52
A2.4.1	Pump controller communications	52

For return of equipment, complete the HS Forms at the end of this manual.

# Illustrations

Figure	Page
1	iXL applications chart ..... 2
2	The controls/connectors ..... 3
3	The front control and indicator panel ..... 4
4	Centre of gravity and levelling foot loads ..... 6
5	Connect the electrical supply ..... 19
6	Electrical connector locking mechanism ..... 20
7	Accessories ..... 39

# Tables

Table	Page
1	General technical data ..... 5
2	General technical data ..... 5
3	Levelling foot loads (refer to Figure 4) ..... 6
4	General electrical data ..... 7
5	Electrical ratings: ultimate vacuum and extracted (700 torr) exhaust load condition ..... 7
6	Electrical ratings: full load conditions ..... 8
7	Electrical ratings: over-load condition (175% full load for 60s) ..... 8
8	Branch circuit protection / fusing ..... 9
9	Electrical connections ..... 9
10	Input supply wire assembly ..... 10
11	Water cooling system data ..... 11
12	Nitrogen supply ..... 11
13	Tool connectors and mating tool connector kits ..... 21
14	Tool input signals to the pump system ..... 21
15	Pump protection sensors ..... 25
16	Disconnect box ..... 35
17	EMS button ..... 36
18	Accessories modules ..... 36
19	PDT ..... 36
20	PDT adaptor cable ..... 36
21	PDT holster ..... 36
22	PDT extension cable ..... 37
23	Lifting / seismic / stacking brackets ..... 37
24	Water flow control valve ..... 37
25	Stainless steel water fittings ..... 37
26	Main power connector ..... 37
27	EMS terminator plug ..... 38
28	Interface modules ..... 38
A1	Pump start / stop and control ..... 42
A2	Pump start / stop and control ..... 42
A3	Normal menu ..... 43
A4	Status menu ..... 43
A5	Setup menu ..... 44
A6	Commands menu ..... 44
A7	Display inverter fault history menu ..... 44
A8	Fit accessory menu ..... 45
A9	IP configuration menu ..... 45
A10	Display menu ..... 46
A11	Display menu select line ..... 46

A12	Display menu units .....	46
A13	Warnings .....	47
A14	Alarms .....	49
A15	Hexadecimal to digital conversion .....	50
A16	Inverter alarm codes .....	50
A17	Inverter warnings codes .....	51

## Associated publications

### Publication title

### Publication number

Vacuum pump and vacuum system safety	P400-40-100
Semiconductor pumping application guide	P411-00-090

## Trademark credits

Han<sup>®</sup> is a registered trademark of Harting Electric GmbH  
 EtherCon<sup>®</sup> is a registered trademark of Neutrik<sup>®</sup> AG  
 Fomblin<sup>®</sup> is a registered trademark of Solvay Solexis SpA

# 1 Introduction

## 1.1 Scope and definitions

This manual provides installation, operation and maintenance instructions for the Edwards iXL120 Pump. You must use your pump as specified in this manual otherwise the protection provided by the equipment may be impaired.

Read this manual before you install and operate your pump. Important safety information is highlighted as **WARNING** and **CAUTION** instructions; you must obey these instructions. The use of **WARNINGS** and **CAUTIONS** is defined below.



### **WARNING**

Warnings are given where failure to observe the instruction could result in injury or death to people.

### **CAUTION**

Cautions are given where failure to observe the instruction could result in damage to the equipment, associated equipment and/or process.

The units throughout this manual conform to the SI international system of units of measurement.

The following warning labels are on the pump and in this manual:



Warning - Refer to accompanying documentation.



Warning - Risk of electric shock.



Warning - Hot surfaces.



Warning - Moving parts present.



Warning - Heavy object.



Warning - Use protective equipment.



Protective Earth (ground).



The following two warning labels, Pressurised and Risk of explosion, only appear in this manual:



Warning - Pressurised.



Warning - Risk of explosion.

Material Safety Data Sheets for chemicals supplied by Edwards can be obtained by contacting Edwards.

## 1.2 Applications

The iXL120 is a low energy, compact dry pump system that can be mounted on tool or remotely. It is designed to give extremely low cost of ownership. The iXL120 is intended only for use on clean duty applications as defined in Figure 1. The iXL120 is not intended for use with potentially flammable, corrosive, toxic or other hazardous gases since these gases or oxygen can mix within the pump system. Users must complete their own risk assessment and implement any necessary controls for pumping potentially flammable gases. Edwards can offer advice and assistance in matching your pump to your application. If you use the iXL120 system on an application for which it is not intended it may invalidate your warranty.

Figure 1 - iXL applications chart

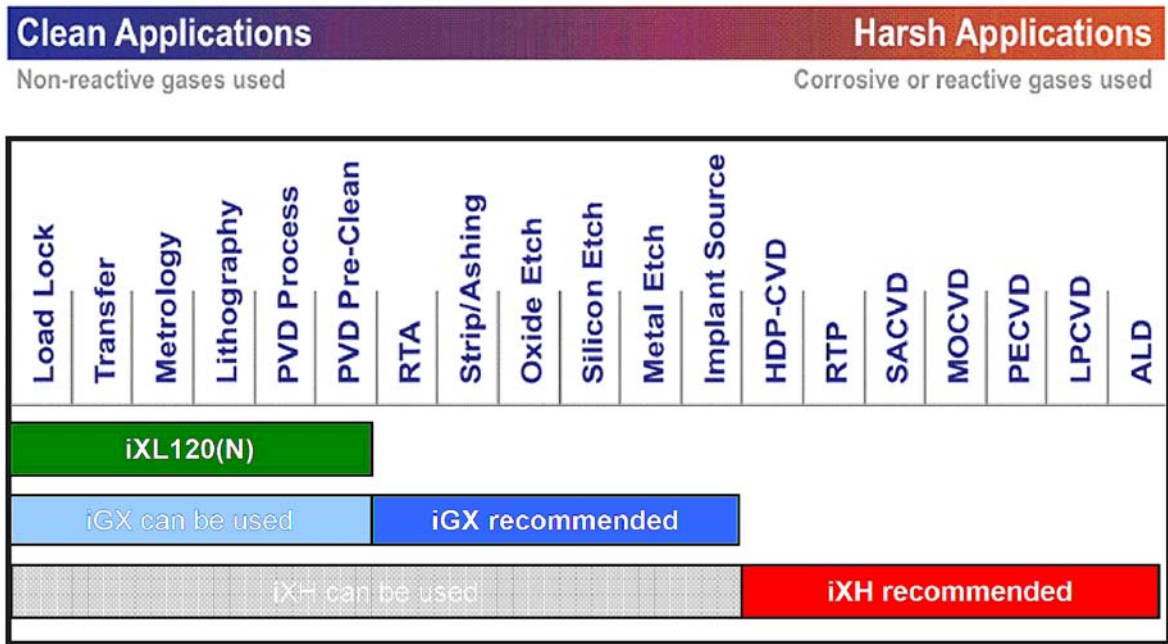

drcs/8604/001



### 1.3 The iXL120 system

The iXL120 is a compact dry pump system that can be mounted on tool or remotely. The pumping system can be controlled from the front control panel, a PDT accessory or by the tool via a MicroTIM.

Figure 2 - The controls/connectors

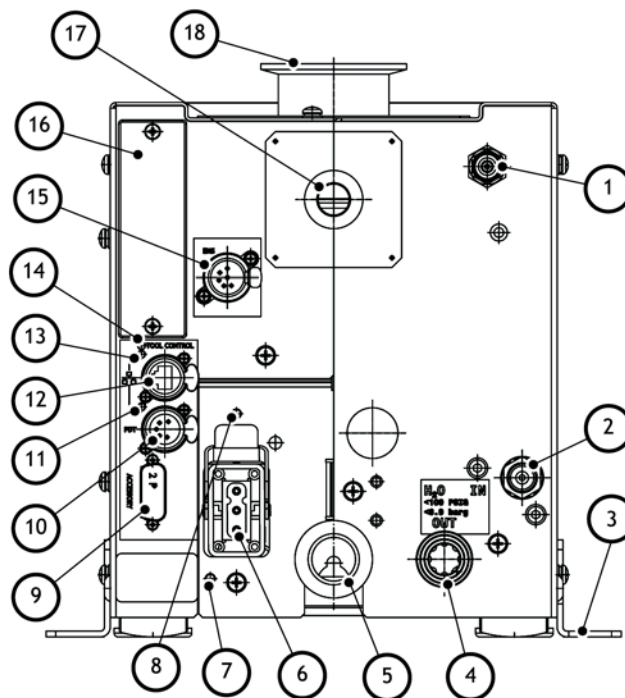

gear/A59140880/fig2

- |   |   |
|---|---|
| 1. Nitrogen purge connection                          | 10. System control/PDT connection           |
| 2. Cooling water supply connection                    | 11. Ethernet installed LED                  |
| 3. Transit/lifting/seismic bracket (if fitted, 2 off) | 12. Ethernet connection                     |
| 4. Cooling water return connection                    | 13. Ethernet active LED                     |
| 5. Exhaust outlet connection                          | 14. Indicator LED - Tool in control         |
| 6. Mains power connection                             | 15. Emergency stop (EMS) connection         |
| 7. Protective Earth (ground) stud M5                  | 16. Tool interface connection               |
| 8. Electrical connector locking mechanism             | 17. Pump inlet gauge port (NW16 connection) |
| 9. Accessory interface                                | 18. Pump inlet (NW50 connection)            |

Figure 3 - The front control and indicator panel

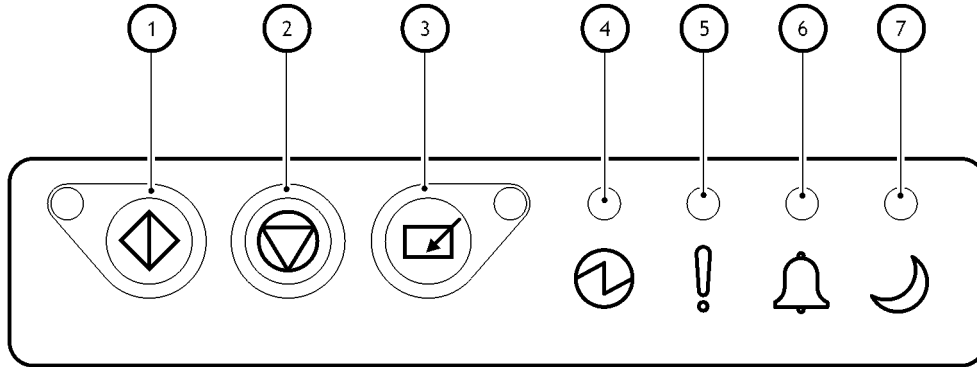

dics/8604/003

Item	Indication
1	Start button/indicator LED (green)
2	Stop button
3	Local control button/indicator LED (green)
4	Power on indicator LED (green)
5	Warning indicator LED (yellow)
6	Alarm indicator LED (red)
7	Idle mode active indicator LED (green)

## 1.4 Priority of control

The iXL120 system can be controlled by one of a number of sources: the front control panel (refer to [Figure 3](#)), a Pump Display Terminal (PDT) accessory or from the tool via the MicroTIM. Only one of these can have control of the iXL120 system at any one time. That is, once one of these has control of the iXL120 system, control requests from the others are denied until control is released by the first.

An LED is provided on the front panel, which illuminates to indicate that the pump is 'in control'. An LED is provided on the rear panel which illuminates to indicate that the tool is 'in control'. The PDT accessory can identify which source is 'in control' and also has an LED to indicate if the PDT itself is 'in control'.

## 2 Technical data

### 2.1 Technical data

**Table 1 - General technical data**

Type	Characteristics	Value	Units
General	Dimensions (L x W x H)	450 x 230 x 275	mm
	Mass (excluding packaging)	59	kg
	Noise level (at ultimate)	<55	dB (A)
	Vibration level at inlet	<1.5	mm s <sup>-1</sup>
	Vibration to the floor (when docked)	<0.05	mm s <sup>-1</sup>
	Initial force to push the pump	0.06	kN
	Sustained force to push the pump	0.04	kN
	Warm up time to nominal pumping performance	45	minutes
Performance	Typical peak pumping speed (no gas purge/cold pump)	110 65	m <sup>3</sup> h <sup>-1</sup> cfm
	Typical ultimate pressure with zero purge	0.013 9.8	mbar mTorr
	Connections	Pump inlet flange Exhaust gas outlet Pump inlet gauge port	NW50 NW25 NW16

**Table 2 - General technical data**

Item	Description	Rating	Units
Operating conditions	Intended use	Indoor use	
	Ambient temperature range:		
	Operating	5 to 40	°C
	Storage	-45 to 55	°C
	Maximum relative humidity:	80% for temperatures up to 31 °C decreasing linearly to 50% relative humidity at 40 °C	
	Maximum operating altitude	Up to 2000	m
	Pollution degree	II (IEC 61010) (Normally only non-conductive pollution occurs. Occasionally, however, temporary conductivity caused by condensation must be expected)	
	Atmosphere	Non flammable and non-corrosive	
Materials in contact with process gas	Pump, shafts and rotors	Cast iron, SG iron, aluminium and steel	
	Seals	PTFE, Methacrylate Ester and Fluoroelastomer	
	Gas system	Stainless steel, aluminium, PTFE and fluoroelastomer	
Degree of protection provided by enclosure	Enclosure protection when installed	IP31D (EN60529: Degrees of protection provided by enclosures)	

## 2.2 Loading

Table 3 - Levelling foot loads (refer to Figure 4)

Levelling foot identifier	Levelling foot load (kg)
1	13
2	12
3	18
4	16

Figure 4 - Centre of gravity and levelling foot loads

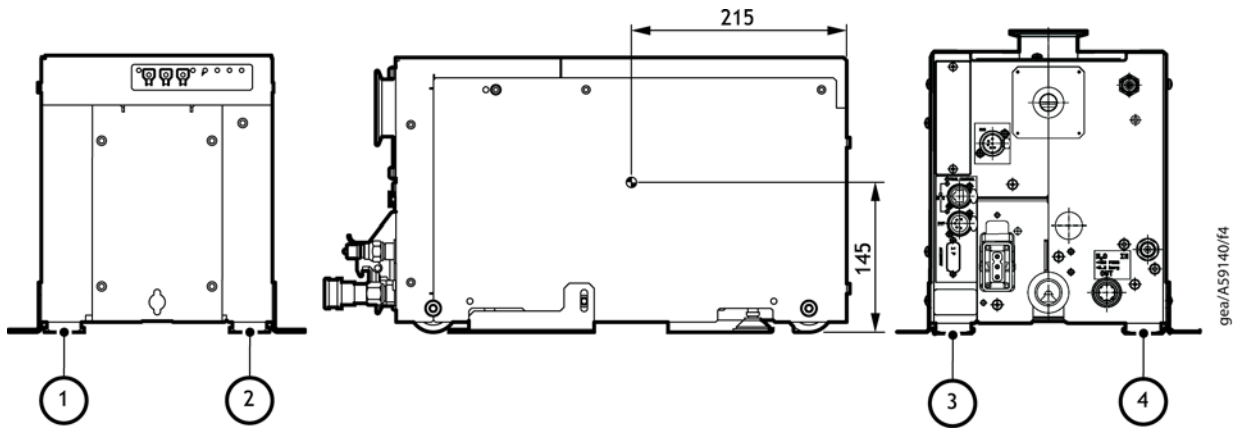

## 2.3 Electrical data

**Table 4 - General electrical data**

Description	Rating	Units
Input supply voltage, 3-phase, a.c., rms	200 - 460 ±10%	V
Input supply frequency	50 - 60 ±5 Hz	Hz
Input supply wiring configuration	3 wire plus Earth (ground)	
Input supply branch circuit protection requirements	Refer to <a href="#">Table 8</a>	
Input supply voltage un-balance	Voltage un-balance should NOT exceed 2%, when assessed over any one minute period.	%
Input supply short-circuit rating	30 (absolute maximum rating)	kA
System Earthing	200 - 240 V: TT; TN and IT (including corner-Earth supplies) 380 - 460 V: TT; TN and IT (excluding corner-Earth supplies)	
Second protective Earth (ground) conductor	Must be fitted with a cross-sectional area at least equal to the phase conductor size.	
Installation category	Over-voltage category II (IEC 60664-1)	
Typical Earth leakage*	<3.5	mA

\* *Typical Earth leakage values were measured at steady-state conditions. Note that higher leakage currents may occur:*

- i) under transient conditions such as power on or pump acceleration or*
- ii) with certain supply configurations such as Earthed phase or*
- iii) with abnormal supply configurations such as a missing phase or unbalanced supply voltages*

*Contact Edwards for more information about configuration requirements for Earth leakage reduction.*

**Table 5 - Electrical ratings: ultimate vacuum and extracted (700 torr) exhaust load condition**

Electrical sub-system: ultimate vacuum (0.01 mbar) load rating*					
Input supply voltage	Input supply frequency	Input supply current		Input supply power	Displayed power / motor power†
(V) (a.c., rms)	(Hz)	(A) (a.c., rms)	(A) (Repetitive Peak)	(kW)	(kW)
200	50	4.0	16.2	0.55	0.52
200	60	3.9	15.2	0.55	0.52
240	50	3.3	13.6	0.55	0.52
240	60	3.2	12.9	0.55	0.52
380	50	2.2	9.0	0.55	0.52
380	60	2.1	8.8	0.55	0.52
460	50	1.8	7.7	0.55	0.52
460	60	1.8	7.5	0.55	0.52

\* *The electrical sub-system ratings, detailed in [Table 5](#), assume an input short-circuit rating of 30 kA.*

† *The displayed power consumption, in [Table 5](#), is a typical value and does NOT include the power consumption of the pump's internal auxiliary power-supply. This auxiliary power-supply is used to power the pump's motor-controller, pump-controller and customer accessories.*

Table 6 - Electrical ratings: full load conditions

Electrical sub-system: continuous / 100% full load ratings*					
Input supply voltage	Input supply frequency	Input supply current		Input supply power	Displayed power / motor power†
(V) (a.c., rms)	(Hz)	(A) (a.c., rms)	(A) (Repetitive Peak)	(kW)	(kW)
200	50	9.5	36.2	1.65	1.53
200	60	10.4	38.9	1.65	1.53
240	50	9.3	35.8	1.65	1.53
240	60	9.0	33.7	1.65	1.53
380	50	5.8	22.5	1.65	1.53
380	60	5.7	21.5	1.65	1.53
460	50	4.8	18.8	1.65	1.53
460	60	4.8	18.1	1.65	1.53

\* The electrical sub-system ratings, detailed in Table 6, assume an input short-circuit rating of 30 kA.

† The displayed power consumption, in Table 6, does NOT include the power consumption of the pump's internal auxiliary power-supply. This auxiliary power-supply is used to power the pump's motor-controller, pump-controller and customer accessories.

Table 7 - Electrical ratings: over-load condition (175% full load for 60s)

Electrical sub-system: over-load ratings*					
Input supply voltage	Input supply frequency	Input supply current		Input supply power	Displayed power / motor power†
(V) (a.c., rms)	(Hz)	(A) (a.c., rms)	(A) (Repetitive peak)	(kW)	(kW)
200	50	15.1	52.9	2.85	2.62
200	60	15.3	54.1	2.85	2.62
240	50	13.4	49.2	2.85	2.62
240	60	14.5	52.8	2.85	2.62
380	50	9.9	36.6	2.85	2.62
380	60	9.6	34.6	2.85	2.62
460	50	8.2	30.2	2.85	2.62
460	60	8.0	28.9	2.85	2.62

\* The electrical sub-system ratings, detailed in Table 7, assume an input short-circuit rating of 30 kA.

† The Displayed Power consumption, in Table 7, does NOT include the power consumption of the pump's internal auxiliary power-supply. This auxiliary power-supply is used to power the pump's motor-controller, pump-controller and customer accessories.

**Table 8 - Branch circuit protection / fusing**

Description	Rating	Units
Minimum fuse current rating	16 - (200 - 240 V a.c., rms / 50 - 60 Hz) 10 - (380 - 460 V a.c., rms / 50 - 60 Hz)	A
Maximum fuse current rating	32 - (200 - 460 V a.c., rms / 50 - 60 Hz)	A
Minimum fuse current breaking capacity	30	kA
Maximum fuse current breaking capacity	200	kA
Fuse voltage rating, a.c., rms	600	V
Recommended UL fuse class <sup>*</sup>	CC, G, J, or RK5	
Recommended IEC fuse type <sup>†</sup>	gG	

<sup>\*</sup> *UL 248 and CSA C22.2 No. 248 low voltage North American Fuses: the recommended fuses provide SLOW protection from inductive and highly inductive loads. This applies to circuits for motors, transformers, lighting and so forth.*

<sup>†</sup> *IEC 60269 low voltage fuses: the recommended fuse type, gG, is a general purpose fuse essentially for conductor protection.*

## 2.4 Electrical connections and cables

**Table 9 - Electrical connections**

Description	Mating connector description / external supply rating	Internal supply rating
Mains connection refer to installation section for wiring diagram	Han-Modular <sup>®</sup> Compact: 40 A; 2.5 - 8 mm <sup>2</sup>	
Ethernet connection	Standard RJ45 type or Neutrik <sup>®</sup> EtherCon <sup>®</sup> RJ45	(IEEE802.3i 10 Base T Ethernet)
System/PDT interface	XLR type 5-way plug	24Vdc, 750mA <sup>*</sup>
EMS External emergency stop switch: 1 - supply; 2 - return Comms 24 V supply: 5 - supply; 6 - return	XLR type 6-way plug	24 V d.c., 100 mA 24 V d.c., 750 mA <sup>*</sup>
Accessory interface Analogue measurement for water flow meter: Pin 1 - input; Pin 5 - common Active accessory module: Pin 3 - RS485 (A); Pin 10 - RS485 (B) Pump running status contacts: Pin 6 - Dry pump running (normally open) Pin 15 - Running common Gate valve: Pin 4 - Gate valve drive transistor (open collector) Gate valve position sense: Pin 7 - 'Closed'; Pin 8 - 'Open'	15-way D-Type socket       30 V a.c., 1A, 60 V d.c., 0.55A	

Table 9 - Electrical connections (continued)

Description	Mating connector description / external supply rating	Internal supply rating
Power supplies: Pin 12 - Accessory 24 V supply (standby) Pin 13 - Accessory 24 V supply (main) <sup>†</sup> Pin 5 - 0 V supply common  Serial comms: Pin 9 - RS232 Transmit Pin 11 - RS232 Receive		24 V d.c., 750 mA*  24 V d.c., 200 mA
Tool interface connection (if fitted)	Refer to Section 3.9	Nominal voltage rating 24 V

\* The System interface, the EMS interface and the Accessory interface give a combined current rating of 750 mA.

<sup>†</sup> This supply will be disconnected in the event of an emergency stop.

Table 10 - Input supply wire assembly

Description	Rating	Units
Minimum conductor cross sectional area	6.0 / 10 (200 - 240 V a.c., rms / 50 - 60 Hz) 2.5 / 12 (380 - 460 V a.c., rms / 50 - 60 Hz)	mm <sup>2</sup> / AWG
Conductor wire type	Stranded wires	
Conductor insulation min temperature rating	75	°C



## 2.5 Cooling water data

Table 11 - Water cooling system data

Description	Rating	Units
Maximum supply pressure	6.9 100	barg psig
Minimum supply pressure	2.5 36	barg psig
Minimum flow rate required*	1	l min <sup>-1</sup>
Cooling-water supply temperature range	10 - 30	°C
Water type	Treated or non-corrosive industrial	
Maximum particle size	0.03	mm <sup>2</sup>
Acidity	6.5 to 8.0	pH
Hardness	< 100	ppm of CaCO <sub>3</sub> (<100 mg of CaCO <sub>3</sub> per litre)
Resistivity	0.001 ≤ ρ ≤ 1	Mohm-cm
Solids (turbidity)	< 100	ppm
Materials in contact with cooling water	Stainless steel, polyamide, fluoroelastomer, nitrile, PVDF and PTFE	
Water inlet connection	per customer specification	
Water outlet connection	per customer specification	

\* The table specifies minimum water flow rate that is required at 30 °C cooling water. The water flow rate can be reduced if colder water is supplied. Contact Edwards for additional information. Maximum flow of 5 l min<sup>-1</sup> to prevent condensation at 10 °C cooling water.

## 2.6 Nitrogen purge system

Table 12 - Nitrogen supply

Gas Module Items	Reference data
Nitrogen supply interface	1/4 inch quick connect fitting
Maximum supply pressure	7 barg, 7 x 10 <sup>5</sup> Pa, 100 psig
Minimum supply pressure	3.0 barg, 3 x 10 <sup>5</sup> Pa, 45 psig
Minimum purity	ISO 8573 solids class 1
Typical flow at 3.0 bar	4 slm

This page has been intentionally left blank.

## 3 Installation

### 3.1 Safety



#### **WARNING**

Obey the safety instructions given below and take the appropriate precautions. If you do not, you can cause injury to people and damage to equipment.



#### **WARNING**

The system should not be operated with the Edwards enclosure panels removed.

Potential hazards on the dry pumping system include electricity, hot surfaces, process chemicals, Fomblin oil, nitrogen and water under pressure.

Detailed safety information is given in [Section 5.1](#) and the Edwards publication 'Vacuum Pump and Vacuum System Safety' (publication number P400-40-100).

- Only Edwards trained engineers may install the dry pumping system. Users can be trained by Edwards to conduct the tasks described in this manual, contact your local service centre or Edwards for more information.
- Do not remove the temporary cover or blanking plate from the dry pumping system inlet and exhaust until you are ready to connect the dry pumping system to your vacuum or exhaust-extraction system. Do not operate the dry pumping system unless the inlet and exhaust are connected to your vacuum and exhaust-extraction system.
- Vent and purge the process system (if the dry pumping system is to replace an existing pumping system) with nitrogen for 15 minutes before you start installation work. Refer to [Section 3.6](#).
- Disconnect the other components in the process system from the electrical supply so that they cannot be operated accidentally.
- Electrical, nitrogen and water supplies are all potentially hazardous energy sources. Before carrying out any maintenance the supply of these sources should be locked and tagged out.
- Route and secure cables, hoses and pipework during installation to avoid possible trip hazards.
- The pump system includes provision for secondary containment of oil and water leaks. Any unintended overflows or spills must be removed immediately to avoid risk of slips.
- Obey all national and local rules and safety regulations when you install the dry pumping system. Consult Edwards publication number P400-40-100 (Vacuum Pump and Vacuum System Safety) before you pump hazardous materials. This publication is available on request: contact your supplier or Edwards.

### 3.2 Removing the iXL120 system from the packaging



**WARNING**

You must use suitable lifting equipment to move the system. It is too heavy to lift by hand.



**WARNING**

Do not exceed the topple angle of 10° when moving the pump. Wheel the system on its castors to move it into its operating position. The system should only be wheeled short distances over flat surfaces. If the floor surface is uneven or has obstacles the system should be lifted with suitable lifting equipment.

1. Cut open bag and expose the brackets which are used to fasten the pump to the pallet.



2. Remove the fasteners at the brackets securing the pump to the pallet.



3. Remove the brackets from the pump.



4. Reattach the brackets at the top front right and top rear left corners using 2 fixings for each bracket.



5. Lift pump using suitable lifting equipment, as shown.



6. Wind up jacking feet until flush with bottom of chassis to expose the castors to allow the pump to be manoeuvred.



7. Lower pump to ground and remove lifting brackets. If stacking pumps then leave these brackets in place and refer to section 3.4.



8. Store the brackets under pump frame for later use.



9. The iXL120 system is ready to be located; please refer to Section 3.3 of the manual.



### 3.3 Locate the iXL120



#### WARNING

You must use suitable lifting equipment to move the system. It is too heavy to lift by hand.



#### WARNING

Do not exceed the topple angle of 10° when moving the pump. Wheel the system on its castors to move it into its operating position. The system should only be wheeled short distances over flat surfaces. If the floor surface is uneven or has obstacles the system should be lifted with suitable lifting equipment.

Use the following procedure to locate the iXL120 system in its operating position. The iXL120 system must be located on a firm, level surface (with less than 3 degrees slope), to ensure that the system is not damaged and operates reliably.

1. Use suitable lifting equipment (refer to [Section 3.2](#)) to move the iXL120 system close to its final operating position.
2. Adjust the levelling feet to make sure that the iXL120 system is level and is not supported by the castors.
3. The lifting brackets should be removed and retained.
4. If you want to secure the iXL120 system in place to prevent inadvertent movement (for example, during an earthquake), take note of the following:
  - The iXL120 system lifting brackets (retained in [Step 3](#) above) can be used for seismic restraint, shown in ([Figure 2](#), item 3). They are designed to withstand a level 4 earthquake in a ground floor installation and are capable of restraining two systems when stacked.
  - The iXL120 system can be secured to the floor by fitting suitable bolts or studs (not supplied) through the slotted hole in the brackets.
  - If vibration transmission to the floor is a concern, suitable vibration isolators (not supplied) should be fitted between the brackets and the bolt or stud.

### 3.4 Connect the iXL120 system to your vacuum/exhaust system and interstage connection (if fitted)



#### WARNING

Pipe the exhaust to a suitable treatment plant to prevent the discharge of dangerous gases or vapours to the surrounding atmosphere.



#### WARNING

Do not operate the system with the exhaust pipeline blocked. If the exhaust pipeline is blocked, the system can generate exhaust pipeline pressures of up to 3.5 bar ( $3.5 \times 10^5$  Pa).

Do not reuse any O-ring or O-ring assembly and do not allow debris to get into the iXL120 system during installation.

When you connect your iXL120 system to your vacuum system, take note of the following:

- To get the best pumping speed, ensure that the pipeline which connects the vacuum system to the iXL120 system is the minimum length possible and has an internal diameter not less than the iXL120 system inlet-port.

- Ensure that all components in the vacuum pipeline have a maximum pressure rating which is greater than the highest pressure that can be generated in your system.
- Incorporate flexible pipelines in the vacuum pipeline to reduce the transmission of vibration and to prevent loading of coupling-joints. We recommend that you use Edwards braided flexible pipelines for exhaust connection.
- Adequately support vacuum/exhaust pipelines to prevent the transmission of stress to pipeline coupling-joints.
- Incorporate a pressure gauge in the inlet pipeline, as an aid to determining that the iXL120 system operates correctly.
- You must be able to isolate the iXL120 system inlet from the atmosphere and from your vacuum system if you have pumped or produced corrosive chemicals.

Refer to [Figure 2](#), items 18 and 5. Use the following procedure to connect the inlet and exhaust of the iXL120 system to your vacuum inlet and exhaust pipeline:

1. Remove the blanking plate from the inlet of the iXL120 system.
2. Use the O-ring and NW50 Clamping ring supplied to connect the inlet-flange ([Figure 2](#), item 18) of the iXL120 system to your vacuum system.

### 3.5 Leak test the iXL120 system



#### **WARNING**

Leak test the system after installation and seal any leaks found to prevent leakage of dangerous substances out of the system and leakage of air into the system.

*Note:* If you need further information on leak-testing, contact Edwards.

### 3.6 Connect the nitrogen supply

#### 3.6.1 Flammable/pyrophoric materials



#### **WARNING**

You must obey the instructions and take note of any precautions given below to ensure that pumped gases do not enter their flammable ranges.

- The iXL120 is not suitable for use with potentially flammable or pyrophoric materials.

When flammable or pyrophoric materials are present within the pump there may be additional risks that the user is responsible for assessing and managing as part of the entire Process Tool installation. The severity of the risks and the necessary control measures will depend largely on whether the tool exhaust is in the flammable region, if this is part of normal Process Tool operation, or if it might only occur under rare conditions. The additional risks arise because all dry pumps must be considered a potential source of ignition owing to the heat of compression, or possibly friction. If ignition occurs then the following may happen:

- High pressures could occur within the pump and may not be contained
- A flame front could travel back up the foreline
- A flame front could travel downstream from the exhaust of the pump.

Industry best practice suggests that the following measures will reduce the risks of pumping flammable mixtures and pyrophoric materials, but it is the user's responsibility to carry out a risk assessment and take appropriate measures:

- Do not allow air to enter the equipment
- Ensure that the system is leak tight
- Ensure that gases in the pump do not enter the flammable range. This may be achieved by diluting gases in the pump by supplying sufficient inert gas purge. For example, dilution with nitrogen to below one quarter LEL (lower explosive limit) or, if that is not practical, to below 60 % LOC (limiting oxidant concentration).
- The gas module supplied with the pump is not intended to perform a safety function. Users may need to consider adding appropriate measures to monitor the flow of purge gas, for example external sensors.

Systems that are fitted with the loadlock gas module must not be used on applications pumping flammable or pyrophoric materials.

For further information please refer to Semiconductor Pumping Application Guide (Publication no. P411-00-090) or contact Edwards.

### 3.6.2 Gas purges



#### **WARNING**

The iXL120 pumps are not suitable for use with hazardous production materials. Any hazardous production materials must be diluted to a safe level before entering the pump.

Gas purge is provided for the sole purpose of enabling the pumping of inert light gases such as helium.

## 3.7 Connect the electrical supply to the dry pumping system



#### **WARNING**

Ensure that the electrical installation of the pumping system conforms with your local and national safety requirements. It must be connected to a suitably fused and protected electrical supply and a suitable Earth (ground) point.



#### **WARNING**

This equipment is suitable for Installation Category II as defined in IEC 60664-1. The dry pumping system must be connected to an isolator that disconnects all current carrying conductors and can be locked in the off position. The isolator must be in close proximity to the equipment, within easy reach of the operator and identified as the disconnect device for the equipment.



#### **WARNING**

The equipment must be permanently Earthed. A second protective Earth (ground) conductor, with a cross-sectional area at least equal to the phase conductor size, must be connected to the protective Earth (ground) stud.



#### **WARNING**

Ensure that the system and your electrical supply cable are suitably protected against Earth (ground) faults and that the Earth (ground) conductor of the electrical supply cable is longer than the phase conductors in the connector.

**WARNING**

All connections to the interface control must be double insulated or have equivalent protection. Do not connect voltages greater than 30 V a.c. or 60 V d.c. to the control/interface connections. If you do, the interface control will not provide protection against electric shock.

**WARNING**

The power wiring must be protected, refer to [Table 8](#) for requirements.

**WARNING**

The main power connector is not approved for connection and disconnection under load.

**CAUTION**

This is an industrial (Class A) product as defined by EN61326. To ensure compliance with European Electromagnetic Compatibility (EMC) requirements for EMC emissions, please note that it is not intended for use in domestic buildings, or in properties directly connected to an electrical supply network which also supplies domestic buildings.

**CAUTION**

Do not connect voltages greater than specified in [Table 9](#) to the control/interface connections. If you do, the interface control may be damaged.

*Note:* The system is protected from motor overloads and short circuits by solid state electronics. The power wiring between the system and your electrical installation must be protected. When selecting input fuse, refer to [Table 8](#). Pump rating information can be found on the label on the rear of the pump.

Refer to [Figure 2](#), item 6.

Use the following procedure and connector components supplied with the pump to connect the electrical supply to the iXL120 system. When you make the electrical supply cable, ensure that the Earth (ground) conductor is slightly longer than the phase conductors. This will ensure that if the cable is accidentally dragged and the strain relief bush on the electrical supply connector mating-half fails, the Earth (ground) conductor will be the last conductor to be pulled from the connector.

You must fit a secondary protective Earth (ground) conductor (with a cross-sectional area at least equal to phase conductor size) to the protective Earth (ground) stud.

1. Attach the strain relief Gland (2) to the Cover Housing (3). Refer to [Figure 5](#).
2. Pass a suitable cable (1) through the strain relief bush and cover. Refer to the technical data section for information on cable sizes.
  - Cables must be bare ended without ferrules to ensure correct clamping in the connector block.
3. Strip back sleeving (50 mm) and insulation (10 mm) on Cable (1). Conductors must not be twisted before fitting to Screw Module (5). Place Gasket (4) over wires
4. Before starting the assembly, use a 2mm Allen key to ensure that the axial cone in the Screw Module (5) is screwed fully downward to completely open the contact chamber.
5. Fit conductors (3 off) to Screw Module (5) and tighten axial cone screw to 1 Nm using a 2 mm A/F hex driver.

*Note:* The manufacturer of the connector states that after initial assembly, the recommended tightening torque must only be reapplied once in order to avoid damage to the individual cable strands.



6. Clip Screw Module (5) into Housing (6) so that terminal number 3 on Screw Module (5) is next to the Earth terminal on Housing (6).
7. Connect the Earth wire of cable (1) to the Earth terminal on Housing (6).
8. Align Housing (6) with hood (3), ensure gasket (4) is in position.
9. Secure Housing (6) to hood (3) using the four screws supplied (7).

Figure 5 - Connect the electrical supply

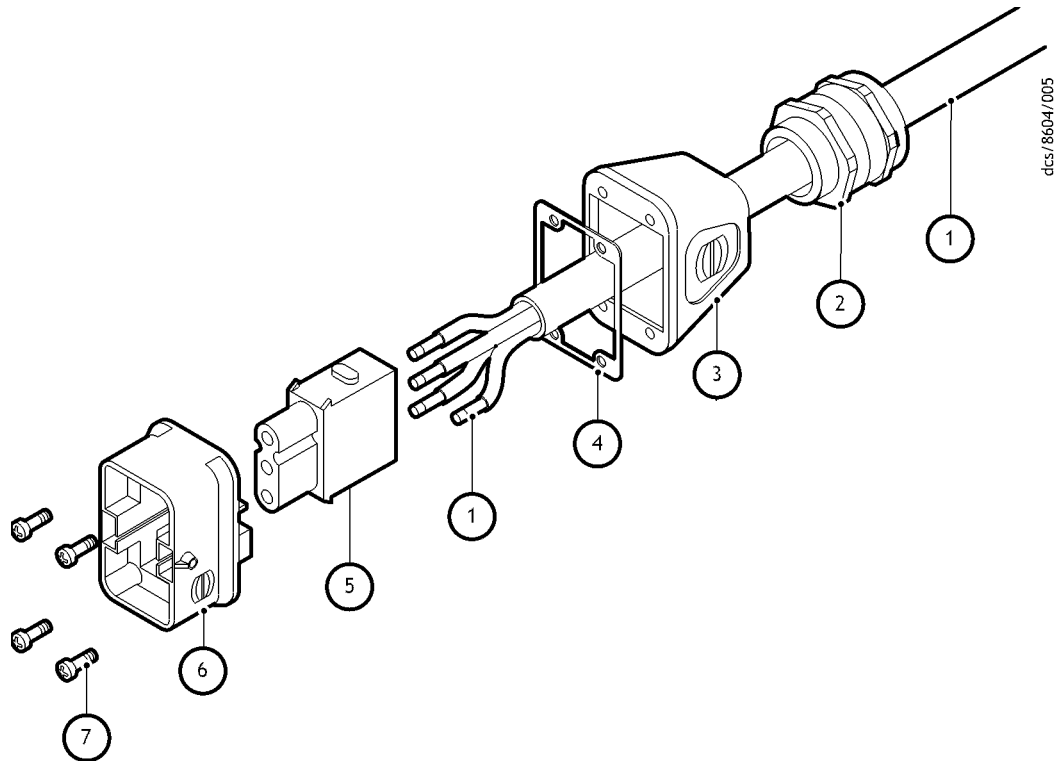

- |                         |                          |
|-------------------------|--------------------------|
| 1. 3-Phase mains cable. | 5. Screw Module (female) |
| 2. Cable gland          | 6. Housing               |
| 3. Hood (M25)           | 7. Screws x 4            |
| 4. Gasket               |                          |

### 3.7.1 Electrical connector locking mechanism

This product is approved permanently connected equipment and must be used as described below.

Figure 6 - Electrical connector locking mechanism



- 1a. Locking mechanism - Locked position
- 1b. Locking mechanism - Unlocked position
- 2. Locking screw
- 3. Lever

The pumping system has an electrical connector locking mechanism [Figure 6](#), which requires the use of a suitable screwdriver to release. The pumping system is supplied with a protective cover fitted and the locking mechanism may be applied. Use the following procedure to fit your electrical supply cable:

1. Refer to [Figure 6](#). Slacken off the locking screw (item 2) by a few turns to loosen the locking mechanism, if necessary.
2. Move the locking mechanism (item 1) to the right as far as possible so that it clears the lever (item 3).
3. Push the lever (item 3) to release the protective cover.
4. Remove the protective cover and fit your electrical supply cable.
5. Pull the lever forwards to secure your electrical supply cable connector in place.
6. Move the locking mechanism to the left as far as possible so that it prevents the lever from actuating.
7. Tighten the locking screw (item 2) to firmly hold the locking mechanism in place.
8. Connect the other end of your electrical supply cable to your electrical supply through a suitable isolator.

### 3.8 Connect to your emergency stop circuit

**CAUTION**

The iXL120 is supplied with an emergency stop circuit. If an emergency stop function is required, then this product can be connected into your own Emergency Stop Control Circuit or the emergency stop button accessory can be used (see [Section 7.3](#)).

**Note:** *If you do not connect to your own control equipment, you must fit the external EMS plug, supplied, to the EMS connector (Figure 2, item 15) on the rear of the iXL120 system. If you do not, you will not be able to operate the iXL120 system.*

If required, you can connect your own control equipment to the iXL120 system to shut it down in an emergency using the EMS connection ([Figure 2](#), item 15 and [Table 5](#)). The emergency stop control must be compliant with IEC 60947-5-1 (This should be a red self latching mushroom push button on a yellow background). An EMS button accessory is available, refer to [Section 7](#).

### 3.9 Connect to your control equipment



#### WARNING

Tool interface control signals are for control purposes only and should not be relied upon for safety critical functions.

#### CAUTION

Do not connect voltages greater than 30 V to the Tool interface control. If you do, the interface control will not comply with the low voltage safety directive and the equipment may be damaged.

The pump may be connected to your control equipment through the MicroTIM (if fitted). The MicroTIM is supplied with a protective plastic cap fitted. Remove this before connecting the mating connector. Several different tool interfaces are available. The label next to the tool connector identifies which type of MicroTIM is fitted, refer to Table 13 to identify the connectors types and mating tool connector kits available (not supplied with the pump). Refer to Table 14 for a definition of the input signals to the pump system.

Table 13 - Tool connectors and mating tool connector kits

Identification	Part Number	Tool Side Connector	Tool Connector Kit
SPI	D37360310	CPC 16/17 Socket	D37420801
MCM	D37360320	CPC 16/17 Socket	D37422802
TEL	D37360330	25w D Type Socket	D37420802
E73	D37360340	15w D Type Plug	D37420803
LAM	D37360350	25w D Type Plug	D37422801
C3	D37360360	9w D Type Socket	D37421803
HIT	D37360370	37w D Type Socket	D37421804

*Note:* Plug/Socket designation refers to the pins of the connector.

#### 3.9.1 Inputs

Table 14 - Tool input signals to the pump system

Function	Signal Type	Pins	Operation
Pump On/Off	Voltage input	SPI - 1 and 2 MCM - 1 and 2 LAM - 10 and 23 C3 - 2 and 6	Pump runs when voltage applied
	Volt-free contact input	MCM - 5 and 6 TEL - 1 and 14 E73 - 1 and 9 HIT - 7 and 26 (or HIT - 1 and 20)	Pump runs when contact closed

*Notes:* 1. Volt free contacts sensed at 24 V / 5 mA, these inputs should not be linked together.

2. Voltage inputs accept AC or DC voltage (except SPI pins 15 and 16), between 15 V and 24 V selects the input as active, below 5 V selects inactive.

3. To ensure correct pump operation, at least 10 seconds must be allowed between successive operations of the input signals.

### 3.10 Connect the cooling-water hoses

---

#### CAUTION

Water only flows if the pump is running or for about 10 seconds when the pump is first energised. You may damage your water circulation system if it cannot tolerate a no flow condition.

---

*Note:* For optimum water-cooling, ensure that your cooling-water supply complies with [Section 2](#) and that the dry pump is not connected in series with any other equipment.

Connect the cooling-water supply as follows:

1. Connect your supply and return hoses to the pump.
2. Turn on the cooling-water supply.
3. Energise the system to ensure water flows through the pump.
4. Inspect the water hoses, pipelines and connections and check that there are no leaks.

Turn off the water supply while you complete the remainder of the installation procedures.

### 3.11 Commission the iXL120 system

---

#### WARNING



During some application cycles it is possible that the system may exceed OSHA 1910.95 Occupational Noise Exposure Limits, the EU noise directive 2003/10/EC or other regional noise limits dependent upon the process, duty cycle, installation or environment in which the system is being operated. A sound pressure survey must be conducted after installation and, if necessary, controls implemented to ensure that the relevant limits are not exceeded during operation and that adequate precautions are taken to prevent personnel from exposure to high noise levels during operation.

---

1. Switch on the external electrical supply and check that the power OK LED ([Figure 3](#), item 4) is lit. If the LED is not lit, contact Edwards.
2. Switch on the cooling-water supply.
3. Ensure that the exhaust-extraction system is not blocked (for example, that valves in the exhaust-extraction system are open).
4. Ensure that all openings to atmospheric pressure in the foreline vacuum system are closed.
5. Press local control button ([Figure 3](#), item 3). The green LED will illuminate. Then press the Start button ([Figure 3](#), item 1).
6. If the iXL120 system starts and continues to operate, continue at [Step 7](#). If a warning or alarm condition is indicated:
  - Shut-down the iXL120 system: refer to [Section 4.3](#).
  - Contact Edwards.
7. After you have commissioned the iXL120 system:
  - If you want to continue to operate the iXL120 system, refer to [Section 4.1, Step 6](#).
  - Otherwise, shut-down the system: refer to [Section 4.3](#).

## 4 Operation



### **WARNING**

Do not operate the system with any enclosure panels removed or damaged and do not touch any parts of the pump(s) when the system is on. Surfaces of the pump(s) are very hot and can cause injury to people.



### **WARNING**

Do not operate the system with any enclosures removed or damaged. If you do there may be a risk of an electric shock.

### 4.1 Start-up



### **WARNING**

Ensure that it is safe to start the system. If you do not (and, for example, maintenance is being performed on components downstream of the system), you could cause injury to people.



### **WARNING**

After the power is applied, all mains circuits will be energised.

### **CAUTION**

The system is designed to ride through short term power interruption and to automatically restart once the power is restored.

### **CAUTION**

Do not operate the pump if the exhaust pipeline is restricted or blocked as the pump will not operate correctly and may be damaged.

1. Switch on the electrical supply.
2. Switch on the cooling-water supply.
3. Check that the exhaust-extraction system is not restricted, and that any valves in the exhaust-extraction system are open.

The pump can be started using the front panel control, the MicroTIM or the PDT.

#### Front control panel operation:

4. To operate the system using the front control panel (refer to [Figure 3](#));
  - Press and hold the 'Local Control' button ([Figure 3](#), item 3). The Green LED will illuminate when control is taken. The message 'Keys in Control' will be displayed on the PDT if connected.
  - Press and hold the Start button ([Figure 3](#), item 1) until pumps starts and the Running LED ([Figure 3](#), item 1) is illuminated.

**PDT operation:**

5. If the system is to be operated using a Pump Display Terminal (PDT);
  - Connect the PDT to the PDT connection (Figure 2, item 10).
  - Control must be taken with the PDT - press 'Control' button. The message 'PDT1 IN CONTROL' will be displayed.
  - Press Start button.
  - Press ENTER.

The system will start and the Running LEDs will be illuminated.

**MicroTIM operation:**

6. Use your Tool control equipment to set the pump start/stop signal to the interface connector and check that the Running LED is illuminated. Check that the 'Tool In Control' indicator LED illuminates when the Tool is in control. The message 'MicroTIM IN CONTROL' will be displayed on the PDT if connected.

## 4.2 Status indicators

Refer to Figure 2 and Figure 3.

## 4.3 Manual shut-down



### **WARNING**

If you shut the system down and don't isolate it from the electrical supply, do not release control. If you do the system could be started by another Module.



### **WARNING**

Do not remove the inlet connections until the pump has been allowed to stop rotating and the power has been isolated. The pump can take up to three minutes to completely stop.

The pump can be shut down using either a PDT, a MicroTIM or the front control panel. Note that only the item in control can stop the pump (refer to Section 1.4). If the pump is not going to be required for some time, switch off the electrical supply and the cooling-water supply.

**Front control panel operation:**

Press and hold the stop button (Figure 3, item 2) until the running LED (Figure 3, item 1) flashes. The running LED will then turn off when the pump has shutdown.

**PDT operation:**

Selecting either 'normal' or 'fast' shutdown will shut the pump down immediately.

**MicroTIM operation:**

Use your control equipment to reset the pump start/stop signal to the interface connector. The Running LED (Figure 3, item 1) will then go off, and the pump running status output signal will open.

## 4.4 Automatic shut-down

### *CAUTION*

If you select 'Run 'til crash', the pump(s) can be damaged and you may invalidate any warranties on the iXL120 system equipment.

Normally, if an alarm condition exists, the iXL120 control system will shut down the iXL120 system. If required you can request 'run 'til crash' operation. In this mode of operation, most alarm conditions will be ignored and the pump(s) will continue to operate. For safety reasons the following alarms will shut down the iXL120 system even if you have selected 'run 'til crash':

- POWERLOSS.
- EMS (emergency stop command).
- DP ACTUAL SPEED (rotational speed below 7 Hz for 3 minutes).
- DP THERMISTOR HIGH (risk of damage to pump due to high temperatures).
- DP STATUS.
- OVERI (motor over current).
- DESAT (drive internal fault).

*Note:* 'Run 'til crash' is automatically reset to 'off' when the electrical supply is removed.

## 4.5 Unplanned shut down and alarms

The iXL120 system is fitted with a number of pump protection sensors (refer to [Table 15](#)) that can, if necessary, give warnings and alarms. The tool can determine whether or not to shut down the pump in response to warnings and alarms.

If the iXL120 system has an unplanned shut down or alarm, ensure that the cause of the shut down or alarm is identified and rectified before restarting. If you have a PDT connected to the pump then you should note and record any warning or alarm codes that are displayed (see [Appendix A2](#)) to assist with identifying the root cause of the shut down or alarm. If you are in any doubt, please call an Edwards Service Engineer.

**Table 15 - Pump protection sensors**

Sensor	Shut-down condition
Dry pump rotational speed	If the pump rotates at less than 7 Hz for more than 3 minutes, then power to the motor will be interrupted to prevent the motor rotor from demagnetising.
Dry pump body temperature sensor	A warning will be generated if the sensor temperature exceeds 104°C. The pump will slow down if the sensor temperature exceeds 109°C. Power is shut-off to the motor if the sensor temperature exceeds 112°C (warning 110°C). This is to prevent the motor from demagnetising.
Motor-controller thermistor	During steady-state/continuous running, the power delivered to the motor is reduced linearly if the motor controller temperature approaches 67°C. This will result in a reduction of motor speed. During short term overload conditions, power is shut-off to the motor if the motor controller temperature exceeds 110°C. This will only occur in an extreme fault condition.

## 4.6 Emergency stop (EMS)

---

### CAUTION

The iXL120 is not fitted with an Emergency Stop Button. If an emergency stop function is required, then this product can be connected into your own Emergency Stop Control Circuit or an EMS button accessory can be fitted (see [Section 7.3](#)).

---

To shut down the iXL120 system in an emergency, you can operate the emergency stop controls in your own control system if you have connected your emergency stop circuit to the iXL120 system as described in [Section 3.7.1](#).

When emergency stop is selected:

- The pump is stopped.
- The thermal management system, (water supply control valve), remains active until the pump system control temperature decreases to a defined level.
- The Pump Display Terminal will display 'STOP ACTIVATED' (If connected).
- The Running LED will go off (refer to [Figure 3](#), item 1).
- The Alarm LED illuminates (refer to [Figure 3](#), item 6).

## 4.7 Restart the pump after an emergency stop or automatic shut-down

If the iXL120 system has been automatically shut down because of an alarm condition, the alarm condition must be rectified before you can restart the iXL120 system. If a PDT is being used then record any alarm codes generated before restarting the pump (refer to [Appendix A2](#)). Restart the iXL120 system as described in [Section 4.1](#).

## 4.8 Auto Tune

Variation in foreline length and architecture combined with differences from pump to pump can lead to variations in vacuum performance. Auto Tune compensates for these variations to give a consistent vacuum performance. The Auto Tune process adjusts the pump running speed so that a specified foreline pressure is achieved for a given flow of gas.

### 4.8.1 Auto Tune requirements

The user must ensure that:

- An active pressure gauge is installed at the chamber and is configured as the Auto Tune source and that
- A constant flow of gas is maintained for the duration of the Auto Tune process.

The user determines the chamber pressure that is to be achieved.

### 4.8.2 Accessing Auto Tune

Auto Tune is initiated by the PDT. From the Setup menu on the PDT, use the up and down arrows to scroll to Auto Tune - press ENTER.



### 4.8.3 Auto Tune configuration

The target chamber pressure and other Auto Tune parameters can be configured using the PDT by the Auto Tune configuration menu. From the Auto Tune menu, use the up and down arrows to scroll to Auto Tune Cfg... - press ENTER.

To set the target pressure

1. Select Target Pressure on Auto Tune Cfg... Menu.
2. Press ENTER.
3. Use up and down arrows to set target pressure.
4. Press ENTER to confirm.

All other parameters are set to factory defaults. Please contact Edwards for advice on setting these values for your application.

### 4.8.4 Starting the Auto Tune process

From the Auto Tune menu on the PDT:

1. Scroll down to Run and Stop - press ENTER.
2. The message displayed will be YES (press ENTER).
3. Press ENTER to confirm.

The Auto Tune process will start automatically and will run until completion. This will normally take several minutes.

The running speed determined during the process will be saved as the normal speed for the pump.

### 4.8.5 Monitoring Auto Tune progress

While the Auto Tune process is running it is possible to monitor progress by the Status option on the Auto Tune menu. Information such as current pressure reading from the gauge, the current speed setting and the time left until the next step in the process is available. There are two status pages available - use the up and down arrows to view them.

### 4.8.6 Cancelling the Auto Tune process

To cancel the Auto Tune process while it is running:

1. Select Run and Stop from the Auto Tune menu.
2. Use the up and down arrows to display STOP and Reset.
3. Press ENTER to confirm.

The Auto Tune process will stop and the normal running speeds will be set back to untuned default values.

### 4.8.7 Returning the pump to factory default speeds

To return the pump to factory default speed select STOP and Reset from the Run and Stop menu. This command will always reset the pump and booster speeds back to their untuned defaults, even if the Auto Tune process is not running.

#### 4.8.8 Important notes about Auto Tune

The Auto Tune process is not a dynamic chamber pressure control function. It is intended only as a way of removing variation when the pump is installed.

The Auto Tune process cannot be used to achieve a pump speed higher than full speed. It is not possible to increase performance using this function.

The Auto Tune settings are pump-specific, they are not stored in the MicroTIM. If the pump is replaced, the Auto Tune process must be performed on the replacement pump.

## 5 Maintenance



**WARNING**

Isolate the electrical supply before working on the equipment.



**WARNING**

Having isolated the electrical supply from the pumping system, wait for at least 4 minutes for the equipment's capacitors to discharge to safe voltage levels (<50 V) before disconnecting the electrical supply cable.



**WARNING**

Only personnel specially trained to perform electrical maintenance should attempt troubleshooting inside electrical enclosures. These enclosures contain hazardous voltages and are not operator areas.



**WARNING**

Leak test the system after maintenance and seal any leaks found to prevent leakage of dangerous substances out of the system and leakage of air into the system.

### 5.1 Safety and maintenance frequency



**WARNING**

Electrical, nitrogen and water supplies are all potentially hazardous energy sources. Before carrying out any maintenance the supply of these sources should be locked and tagged out.



**WARNING**

Personal protection equipment should be checked and used as specified by its supplier. Hazardous chemicals that have been pumped are located within the pumps and piping. Use of suitable protective gloves and clothing along with a respirator is recommended if contact with substances is anticipated.



Particular caution should be exercised when working with Fomblin<sup>®</sup> oil and other fluorocarbon materials such as some seal materials which may have been exposed to temperatures greater than 260 °C. Refer to Edwards Material Safety Data Sheets for detailed information.



- Ensure that the maintenance technician is familiar with the safety procedures which relate to the process products pumped.
- Allow the pumps to cool to a safe temperature before you fit lifting brackets or start maintenance work.
- Vent and purge the dry pumping system with nitrogen before you start any maintenance work.
- Isolate the dry pumping system and other components in the process system from the electrical supply so that they cannot be operated accidentally. Note that the emergency stop function on the dry pumping system is not an electrical isolator, unless a disconnect box accessory is installed.

- Wait for at least four minutes after you have switched off the electrical supply before you touch any electrical component on the dry pumping system.
- Route and secure cables, hoses and pipelines during maintenance to avoid possible risk of trips or entrapment.
- Ensure that any oil or water collected in the secondary containment drip tray is removed before moving the system.
- The enclosure panels should only be removed with the use of a special tool, when the system has been switched off and allowed to cool sufficiently.
- Wear the appropriate safety-clothing when you come into contact with contaminated components. Dismantle and clean contaminated components inside a fume-cupboard.
- Take care to protect the sealing-faces from damage.
- Do not touch or inhale the thermal breakdown products of fluorinated materials which may be present if the iXL120 system has been overheated to 260 °C and above. These breakdown products are very dangerous. Fluorinated materials in the iXL120 system may include oils, greases and seals. The iXL120 system may have overheated if it was misused, if it malfunctioned or if it was in a fire. Edwards Material Safety Data Sheets for fluorinated materials used in the pump are available on request: contact your supplier or Edwards.

## 5.2 Relocate the system for maintenance



### WARNING

The substances that accumulate in the exhaust-pipe, elbow and check-valve (supplied separately) can be dangerous. Do not allow these substances to come into contact with your skin or eyes. Do not inhale vapours from these substances. Fit blanking caps to the inlet and outlet flanges when you move the exhaust-pipe, elbow or check-valve around your workplace.



The majority of synthetic oils/grease can cause inflammation of the skin (dermatitis). Safety precautions must be taken to prevent prolonged skin contact with these substances. Use of suitable protective gloves and clothing along with a respirator is recommended if contact with the substance is anticipated.



System process gases and residue can be highly toxic. Take all necessary precautions when handling components that have, or could have, come into contact with them, including O-rings, lubricants and all exhaust accessories.



### WARNING

You must use suitable lifting equipment to move the system. It is too heavy to lift by hand.



### WARNING

Do not exceed the topple angle of 10° when moving the pump. Wheel the system on its castors to move it into its operating position. The system should only be wheeled short distances over flat surfaces. If the floor surface is uneven or has obstacles the system should be lifted with suitable lifting equipment.

### CAUTION

Drain the cooling-water from the iXL120 system as stated in [Section 5.3](#) if you will transport or store it in conditions where the cooling-water could freeze. If you do not, cooling-water may freeze in the iXL120 system and damage the pump(s) and/or the cooling-water pipelines.

If you want to remove the iXL120 system from its operating location and move it to another location where you will do maintenance, use the following procedure:

1. Purge the iXL120 system and shut down the iXL120 system as described in [Section 4](#) and allow the iXL120 system to cool down.
2. Isolate the power by disconnecting the mating-half from the electrical supply connector, then isolate the water supply.
3. Switch off your cooling water supplies. Disconnect the cooling-water supply followed by the cooling-water return.
4. Disconnect the inlet and outlet from the vacuum and exhaust systems and fit blanking caps.
5. Adjust the levelling feet so that the iXL120 system rests on the castors.
6. Move the iXL120 system to a location where it can be safely stored until an Edwards service engineer can be in attendance.

After maintenance is complete, re-install the iXL120 system as described in [Section 3](#).

### 5.3 Draining the cooling water

---

#### WARNING



Use of suitable protective gloves and eye protection is recommended when carrying out this procedure. Personal protective equipment should be checked and used as specified by its supplier.

- 
1. Relocate the system for maintenance as stated in [Section 5.2](#).
  2. Connect a regulated clean dry air supply (1.4 barg or 20 psig) to the cooling water supply connection ([Figure 2](#), item 2). Do not turn on the air supply yet.
  3. Connect a drain hose to the cooling water return connection ([Figure 2](#), item 4). Position the open end of the drain hose in a suitable collection container.
  4. Turn on the clean dry air supply.
  5. Monitor the drain hose outlet until no further cooling water is purged.
  6. Fit the external EMS link plug (supplied) to the EMS connection on the rear of the system ([Figure 2](#), item 15). If you do not, you will not be able to purge the water system effectively.
  7. Connect the system to a suitable mains electrical supply. The control system will now energise each temperature control valve, purging the cooling water from all flow paths. After one minute, remove the electrical supply. Wait for 10 seconds and then re-connect the electrical supply and repeat the entire process. Continue repeating until no further cooling water is purged from the system.
  8. The cooling water drain procedure is now complete. Disconnect the air supply, electrical supply and the drain hoses. Dispose of the drained cooling water appropriately.

## 5.4 General maintenance

---

### *CAUTION*

Do not use cleaning materials based on strong alkalis, aggressive or chlorinated solvents. Do not use cleaning materials containing abrasives.

---

The system is given a charge of oil before it leaves the factory. There is no requirement to adjust the oil level.

You can conduct the following maintenance on the system when necessary or if you have a problem, contact Edwards for details and training:

- Inspect the connections, pipelines, cables and fittings, refer to [Section 5.5](#).

## 5.5 Inspect the connections, pipelines, cables and fittings



### *WARNING*

Electrical, nitrogen and water supplies are all potentially hazardous energy sources. Before carrying out any maintenance the supply of these sources should be locked and tagged out.

---

If the system is not relocated for maintenance, ensure all supplies are locked out and tagged out before starting the following procedure.

1. Remove the enclosure side panels.
2. Check that all the connections are secure; tighten any loose connections. Inspect all cables, pipelines, hoses and connections and check that they are not corroded or damaged and do not leak; repair or replace any pipelines, hoses and connections that are corroded or damaged, or which leak.
3. Refit the enclosure side panels.

## 6 Transportation, storage and disposal

### 6.1 Transportation



#### **WARNING**

Do not drain the oil from the pump(s) whether dangerous substances have been pumped or not. You must fit blanking plates to seal all vacuum inlet and outlet ports (to prevent possible oil leakage). You must ensure that the system is correctly labelled, if in doubt contact Edwards.

Follow the procedure laid out in [Section 6.2](#) and then read form HS1 and fill out form HS2, which can be found at the back of this manual.

### 6.2 Storage

Drain the cooling-water from the system if you will transport or store it in conditions where the cooling-water could freeze (refer to [Section 5.3](#)). If you do not, the cooling-water may freeze in the system and damage the pump(s) and/or the cooling-water pipelines.

Store the system as follows:

1. Follow the procedure set out in [Section 5.2](#).
2. Store the system in clean dry conditions until required.
3. When required for use, prepare and install the system as described in [Section 3](#) of this manual.

### 6.3 Disposal



#### **WARNING**

Dispose of the system and any components safely and in accordance with all local and national safety and environmental requirements.

This equipment may contain a lithium manganese dioxide battery which, under California law, requires notification for the presence of perchlorate: Perchlorate Material - special handling may apply, refer to [www.dtsc.ca.gov/hazardouswaste/perchlorate/](http://www.dtsc.ca.gov/hazardouswaste/perchlorate/)

Edwards products are supported by a world-wide network of Edwards Service Centres. Each Service Centre offers a wide range of options including disposal. Refer to [Section 7.2](#) for more information.

Pump system materials suitable for recycling include cast iron, steel, SG iron, PTFE, stainless steel, brass, aluminium, zinc alloy, nickel, mild steel, ABS, polyamide.

Take particular care with the following:

- Fluoroelastomers which may have decomposed as the result of being subjected to high temperatures.
- Components which have been contaminated with dangerous process substances.
- Lithium battery.

This page has been intentionally left blank.



# 7 Service, spares and accessories

## 7.1 Introduction



### WARNING

Whenever you return the system to an Edwards Service Centre or other Edwards company, you must comply with the requirements of [Section 7](#) and with the requirements of the Return of Edwards Equipment Procedure (refer to forms HS1 and HS2 at the rear of this manual).

*Note:* You must not drain the oil from the pumping system. You must clearly state the pump is full of oil when you complete form HS2.

Edwards products, spares and accessories are available from Edwards companies and distributors world-wide. The majority of these centres employ Service Engineers who have undergone comprehensive Edwards training courses. Order spare parts and accessories from your nearest Edwards company or distributor. When you order, please state for each part required:

1. Model and Item Number of your equipment.
2. Serial number (if any).
3. Item Number and description of the part.

## 7.2 Service

Edwards products are supported by a world-wide network of Edwards Service Centres. Each Service Centre offers a wide range of options including: equipment decontamination; service exchange; repair; rebuild and testing to factory specifications. Equipment that has been serviced, repaired or rebuilt is returned with a full warranty. Your local Service Centre can also provide Edwards engineers to support on-site maintenance, service or repair of your equipment. For more information about service options, contact your nearest Service Centre or other Edwards company.

## 7.3 Accessories

The accessories available for use with the iXL120 dry pump system are described in the following sections. [Figure 7](#) shows how the accessories are fitted to the iXL120 dry pump system.

### 7.3.1 Disconnect box

The disconnect box ensures full compliance with SEMI S2 by providing true EMO functionality.

Table 16 - Disconnect box

Item	Item number
Disconnect box 200-460 V 50-60 Hz	A50806000

### 7.3.2 EMS button

An emergency stop button can be mounted on the dry pump and allows external connection to an EMS circuit.

Table 17 - EMS button

Item	Item number
EMS button	D37491500

### 7.3.3 Accessory modules

Two accessory modules are available for the iXL120 dry pump system. The Active Accessory Module (AAM) provides connectivity for up to three directly connected accessories including a gate valve, abatement and water flow sensor, plus up to two supported active accessories, two thermocouples and the pump status output. The Passive Accessory Module (PAM) allows up to 3 accessories to be connected to the accessory module interface.

An accessory module extension cable allows the AAM or PAM to be mounted up to 5 m away from the dry pump system.

Table 18 - Accessories modules

Accessory module	Item number
AAM*	D37480500
PAM*	D37480550
Accessory module extension cable (5 m)	D37491502

\* The AAM and PAM cannot be mounted directly on the iXL120. Contact Edwards for details.

### 7.3.4 Pump Display Terminal (PDT)

The PDT allows control and monitoring of the iXL120.

Table 19 - PDT

Item	Item number
PDT	D37280700

### 7.3.5 PDT adaptor cable

The PDT adaptor cable allows a second PDT to be connected to the iXL120.

Table 20 - PDT adaptor cable

Item	Item number
PDT adaptor cable	D37491501

### 7.3.6 PDT holster

The PDT holster retains the PDT and is attached to the pump or tool frame.

Table 21 - PDT holster

Item	Item number
PDT holster	D37209800

### 7.3.7 PDT extension cable

The PDT extension cable allows a PDT to be used away from the pump.

Table 22 - PDT extension cable

PDT extension cable	Item number
3 m	D37370591
5 m	D37370592
10 m	D37370595
15 m	D37370596
25 m	D37370597

### 7.3.8 Lifting / seismic / stacking brackets (pair)

A pair of bespoke multi-function brackets to allow the lifting and stacking of the pump. These brackets are also used as seismic restraints.

Table 23 - Lifting / seismic / stacking brackets

Item	Item number
Lifting / Seismic / Stacking brackets (pair)	A54050722

### 7.3.9 Water flow control valve (1 lpm)

The Water flow control valve controls the flow of water through the pump to 1 lpm.

Table 24 - Water flow control valve

Item	Item number
Water flow control valve	A50738000

### 7.3.10 Stainless steel water fittings (pair)

The stainless steel water fittings are replacement connectors to mate with those fitted to the pump.

Table 25 - Stainless steel water fittings

Stainless steel water fittings	Item number
1/4 inch BSPP straight quick connect	A50717000
3/8 inch BSPP straight quick connect	A50721000

### 7.3.11 Main power connector

A replacement 3-phase supply and PE connector.

Table 26 - Main power connector

Item	Item number
Main power connector	D37491735

### 7.3.12 EMS terminator plug

A replacement plug to complete emergency stop circuit.

Table 27 - EMS terminator plug

Item	Item number
EMS terminator plug	D37207061

### 7.3.13 Interface modules

Tool specific monitor/control and emergency stop interfaces.

Table 28 - Interface modules

Item	Interface type	Item number
SPI microTIM	Monitor and control	D37360310
MCM microTIM	Monitor and control	D37360320
TEL microTIM	Monitor and control	D37360330
Semi E73 microTIM	Monitor and control	D37360340
LAM Alliance microTIM	Monitor and control	D37360350
Hitachi microTIM	Monitor and control	D37360370
iGateway Module	Pump serial to pump LON + 2 x SIM	D37376500
SPI EMS Module	Emergency stop	D37370310
MCM EMS Module	Emergency stop	D37370320
LAM Alliance EMS Module	Emergency stop	D37370350
C3 EMS Module	Emergency stop	D37370360

Figure 7 - Accessories

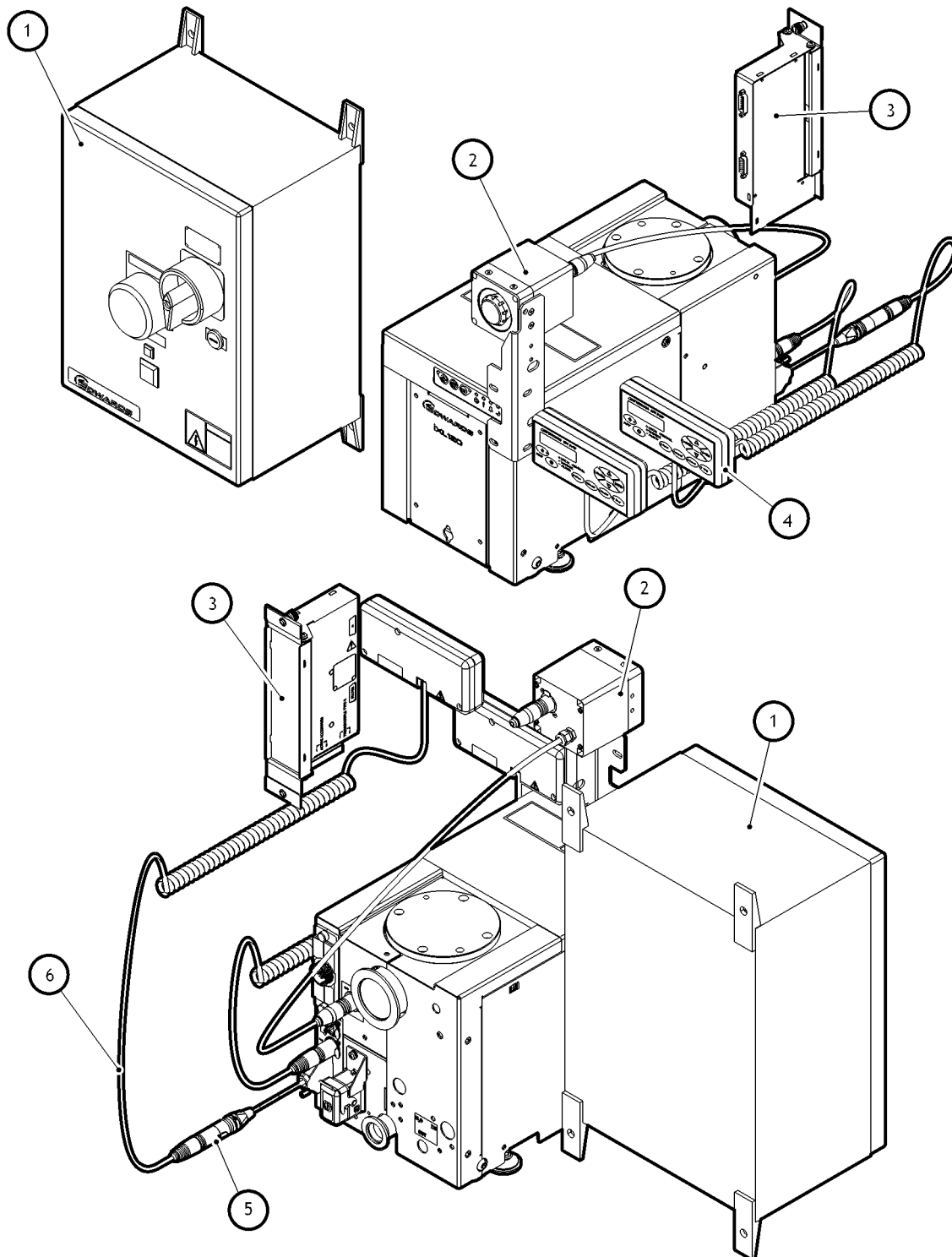

- |                     |                        |
|---------------------|------------------------|
| 1. Disconnect box   | 5. PDT adaptor cable   |
| 2. EMS button       | 6. PDT extension cable |
| 3. Accessory module |                        |
| 4. PDT              |                        |

*Note:* Some cables omitted for clarity

dcsl/8604/008

This page has been intentionally left blank.

# Appendix A1 Pump Display Terminal (PDT)

## A1.1 PDT

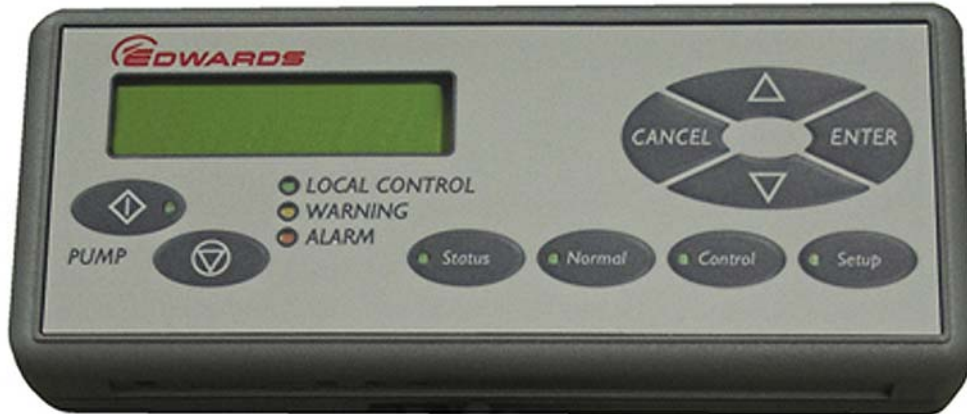

The PDT accessory provides pump on/off and status reporting. Warnings and alarms are also indicated to the user. Up to two PDTs may be fitted to the pump.

### A1.1.1 LEDs

<b>Local Control</b>	Green continuous on when this PDT has control of the pump.
<b>Pump ON</b>	Green (within the Pump Start button) illuminates to indicate that the pump is running.
<b>Warning</b>	Yellow illuminates to indicate that a pump warning is present. It flashes when a new warning occurs until it is acknowledged by pressing <b>ENTER</b> when it goes continuous until the warning clears.
<b>Alarm</b>	Red illuminates to indicate that a pump alarm is present. It flashes when a new alarm occurs until it is acknowledged by pressing <b>ENTER</b> when it goes continuous until the alarm clears.

### A1.1.2 Pump start / stop and control

To Start or Stop the pump the PDT must be in control, indicated by the **Local Control** LED being illuminated.

To take or release control briefly press **Control**.

If something else is in control, error message 'Control locked' appears, refer to 'Control Holder' in the **Status** menu.

Press **Start**  button PDT displays:

**Table A1 - Pump start / stop and control**

Pump State	Local Control LED	PDT display	Operator	Pump response
Stopped	On	START MENU Start Pump	Press <b>ENTER</b> to confirm	Pump Starts
Running	On	Pump Running Press <b>CANCEL</b>	Press <b>CANCEL</b>	No change (running)
Stopped or Running	Off	No PDT Control Press <b>CANCEL</b>	Press <b>CANCEL</b>	No change

Press **Stop**  button PDT displays:

**Table A2 - Pump start / stop and control**

Pump State	Local Control LED	PDT display	Operator	Pump response
Stopped	On	PUMP Stopped Press <b>CANCEL</b>	Press <b>CANCEL</b>	No change (stopped)
Running	On	STOP MENU Fast Shutdown	If Auto Shutdown is required press down arrow. Press <b>ENTER</b> to confirm	Pump Stops
Stopped or Running	Off	No PDT Control Press <b>CANCEL</b>	Press <b>CANCEL</b>	No change

### A1.1.3 Warning / alarm display and acknowledgement

Each new warning / alarm is displayed when it occurs, overwriting any text already present unless another unacknowledged warning / alarm is currently being displayed. The corresponding **Warning / Alarm** LED flashes to indicate a new warning / alarm.

Pressing **ENTER** acknowledges the warning / alarm currently displayed and the **Warning / Alarm** LED stops flashing. If available the display will show the suggested action, press **ENTER** again to clear.

If there is another new warning or alarm the **Warning / Alarm** LED will continue to flash and this is then displayed, otherwise the display will revert to the original text from before the alarm(s) / warning(s) occurred.

If there are warnings / alarms still present, but they are all acknowledged, then the corresponding LED remains continuously illuminated. The text indicating acknowledged warning / alarm conditions still present may be viewed in the **Status** menu, see below. Some Alarms such as 1.01 STOP ACTIVATED remain present until the pump is manually started from the PDT or front panel controls.

Once all warning/alarm conditions have gone away, then the corresponding LED is extinguished.

To avoid a build up of out of date Warnings they are automatically acknowledged after 36 hours.



### A1.1.4 Menus

There are three menu buttons **Normal**, **Status** and **Setup** described below.

NR in the data part of a parameter indicates No Reading.

NP in the data part of a parameter indicates a parameter that is Not Present.

#### A1.1.4.1 Normal menu

This menu is displayed when the PDT is first plugged into the pump, or accessed by pressing Normal button. Up to 4 parameters displayed, scroll by pressing up/down keys.

Table A3 - Normal menu

Description	Typical Display
Serial Number	S/N 1234567
Control Holder	NONE IN CONTROL
Dry Pump current	DP CURRENT 4.0 A
Dry Pump speed	DP SPEED 150 Hz

By default the 4 parameters displayed in the Normal menu are as shown above, these may be changed using Edit Display attributes menu in **SETUP**.

#### A1.1.4.2 Status menu

Press the **Status** button to enter. Scroll by pressing up/down keys. Press **CANCEL** to exit back to **Normal** menu.

If a device is not fitted the associated parameters will not be displayed. Parameters displayed:

Table A4 - Status menu

Description	Typical display
Serial Number	S/N 1234567
Control Holder	NONE IN CONTROL
Dry Pump current	DP CURRENT 4.0 A
Green mode	GREEN MODE Off
Dry Pump temperature	DP TEMP 100 °C
Dry Pump Power	DP POWER 0.52 kW
Dry Pump speed in percent	DP SPEED 100%
Dry Pump speed in Hz	DP SPEED 150 Hz
Dry Pump inverter temperature	DP INV TMP 100 °C
Run Hours	RUN HOURS 1000
Number of Pump Starts	PUMP STARTS 100
Time to Stop (seconds)	TIME TO STOP 900
Active Alarms and Warnings	

**A1.1.4.3 Setup menu**

Press the **Setup** button to enter. Menu title is shown at the top of the display. Scroll by pressing up/down keys. Press **ENTER** to open a sub menu or **CANCEL** to exit back to **Normal** menu.

**Table A5 - Setup menu**

Description	Display
Commands menu*	Command Menu...
Display Inverter Fault History menu	Inv Fault Hist...
Software Version Display menu	S/W Version...
Display Serial Number	Serial Num...
Fit Accessory menu*	Fit Accessory...
Edit IP configuration menu	IP Config...
Edit Display attributes menu	Display Attr...
Set Time and Date†	Set Clock...
Display Pump Type	Show Pump type...

\* This option requires a security code to access it.

† Time is set automatically when connected to a Fabworks network.

Each sub menu is described below.

**A1.1.4.4 Commands menu**

Under the Setup menu. Scroll by pressing up/down keys. Press **ENTER** to open a sub menu or **CANCEL** to exit back to the **SETUP** menu.

**Table A6 - Commands menu**

Gate Valve (Open/Shut)*
Green mode (On/Off)†

\* This option requires a security code to access it.

† The PDT must be in control to perform this function.

Press the up/down keys to select the new settings and press **ENTER** to accept or **CANCEL** to exit back to the **COMMANDS** menu.

**A1.1.4.5 Display Inverter Fault History (inv fault hist) menu**

Under the Setup menu. Scroll by pressing up/down keys. Press **ENTER** to open a sub menu or **CANCEL** to exit back to the **Setup** menu.

**Table A7 - Display inverter fault history menu**

DP Inv Fault Hist (Dry Pump Inverter Fault History)
---

Each inverter fault history contains up to 32 entries, each contains one alarm and one warning, where 1 is the most recent. Scroll by pressing up/down keys. Press **CANCEL** to exit back to the Inverter Fault History menu.

**A1.1.4.6 Software version display menu**

Under the Setup menu. Scroll through the software version loaded in the processors by pressing up/down keys. Press **CANCEL** to exit back to the **SETUP** menu.

### A1.1.4.7 Fit accessory menu

Under the Setup menu. Scroll by pressing up/down keys. Press **ENTER** to open a sub menu or **CANCEL** to exit back to the **Setup** menu.

Table A8 - Fit accessory menu

Item	Description
Gate Valve...	
Water Sensor...	(Analogue water flow)
Active Gauge...	
Exh Gas Temp...	(Exhaust Gas Temperature)

For an accessory press the up/down keys to select Fitted or Not Fitted and press **ENTER** to accept or **CANCEL** to exit back to the **COMMANDS** menu. Gate Valves additionally have an option of Fitted No Feedback for use where there are no position feedback switches fitted to the gate valve.

### A1.1.4.8 IP configuration menu

Under the Setup menu. Scroll by pressing up/down keys. Press **ENTER** to open a sub menu or **CANCEL** to exit back to the **Setup** menu.

Table A9 - IP configuration menu

Item	Description
Host_Name...	(display only)
DHCP Enable...	(Enabled / Disabled)*
IP Address...	(xxx.xxx.xxx.xxx) <sup>†</sup>
Address Mask...	(xxx.xxx.xxx.xxx) <sup>†</sup>
DNS Server...	(xxx.xxx.xxx.xxx) <sup>†</sup>
Gateway...	(xxx.xxx.xxx.xxx) <sup>†</sup>
NTP Server...	(display only)
SMTP Server...	(display only)
MAC Address...	(display only)
Domain Name...	(display only)

\* Press the up/down keys to select Enabled or Disabled and press **ENTER** to accept or **CANCEL** to exit back to the **IP Configuration** menu.

<sup>†</sup> For each address setting press the up/down keys to set the digit, press **ENTER** to accept and move to the next digit or **CANCEL** to move back to the previous digit. Pressing **ENTER** at the end of the line will accept the new setting and exit back to the **Edit IP** menu. Pressing **CANCEL** at the start of the line will cancel and exit back to the **IP Configuration** menu.

Display only items press **CANCEL** to exit back to the **IP Configuration** menu.

**A1.1.4.9 Display menu**

Under the Setup menu. Scroll by pressing up/down keys. Press **ENTER** to open a sub menu or **CANCEL** to exit back to the Setup menu.

**Table A10 - Display menu**

Normal display (Selects the parameters displayed in Normal)
Units...

**SELECT LINE (Normal display selection menu)**

Scroll by pressing up/down keys. Press **ENTER** to open a sub menu or **CANCEL** to exit back to the Display Attributes menu.

**Table A11 - Display menu select line**

Top Page 1...
Bottom Page 1...
Top Page 2...
Bottom Page 2...

In each option the **SELECT PARAMETER** menu is opened, scroll through the parameters by pressing up/down keys. Press **ENTER** to select the parameter for display or **CANCEL** to exit back to the **SELECT LINE** menu.

**UNITS (Units to display)**

Scroll by pressing up/down keys. Press **ENTER** to open a sub menu or **CANCEL** to exit back to the Display Attributes menu.

**Table A12 - Display menu units**

Item	Description
Pressure...	(PSI/kPa)
Temperature...	(Centigrade/Fahrenheit)
Speed...	(RPM/Hz)
Active Gauge...	(mBar/Torr/kPA)

In each option scroll through the units available by pressing up/down keys. Press **ENTER** to select the displayed units or **CANCEL** to exit back to the **UNITS** menu.

# Appendix A2 Troubleshooting

## A2.1 Warnings

The pump controller generates a warning when a problem is encountered. Once the problem that caused a warning has been resolved, the warning is cleared by the pump controller.

### A2.1.1 LED warning indicators

If the pump encounters a problem, warnings are indicated on the LED on the front control panel and on the PDT if fitted.

The warning LED on the front control panel illuminates continuously when a warning is generated.

If a PDT is fitted, the warning LED flashes to indicate a new warning. Refer to [Appendix A1.1.3](#) for more information on how warnings are indicated and how they can be acknowledged using the PDT.

Once all the warnings are cleared, the warning LEDs extinguish. If the warning LED is illuminated then connect a PDT to determine the warning message and refer to Table A13 to identify the possible cause and corrective actions. If no PDT is available then you will have to systematically work through the actions listed in Table A13 until the warning is cleared.

### A2.1.2 PDT warnings

If a PDT is fitted, each warning triggers a warning message to be displayed. Refer to [Appendix A1.1.3](#) for more information on how warnings are handled by the PDT.

[Table A13](#) lists the warning messages that might be displayed on the PDT with possible causes and actions you should take.

Table A13 - Warnings

Warning Message on PDT	'Action' Message on PDT	Possible Cause	Action
Warning 1.01 Power interrupt	Check pwr supply	There has been a brownout of the electrical supply to the pump lasting more than 1 second.	Check the electrical supply
Warning 55.13 Sensor missing	-	The dry pump temperature sensor may have become disconnected or failed.	- Check that the sensor is fitted and is correctly connected.
Warning 71.13 AC Sup Missing	See manual	The pump controller cannot communicate with the accessory module	- Check that the accessory module is correctly connected to the pump and then cycle the power to the pump. - If this warning persists, contact Edwards.
Warning 152.01 Valve Not Shut	Check Gate Valve	The foreline gate valve has failed to close	Check the wiring and air supply to the Gate valve.  <i>Note: This warning will only clear when the valve has successfully been opened and closed.</i>

Table A13 - Warnings (continued)

Warning Message on PDT	'Action' Message on PDT	Possible Cause	Action
Warning 153.01 Valve Not Open	Check Gate Valve	The foreline gate valve has failed to open	Check the wiring and air supply to the Gate valve.  <i>Note: This warning will only clear when the valve has successfully been closed and opened.</i>
Warning 186.01 DP Inverter Warn	Code Axxxx Wyyyy aaaaaaaaaaaaaaaa	Dry pump Inverter has raised a warning code.	Refer to A1.1.3 for more information.
Warning 186.13 No DP Inv Comms	See manual	The pump controller cannot communicate with the dry pump inverter.	Check the wiring between the pump controller and the dry pump inverter.

- Notes:**
1. Some of these warnings apply to pump sensors that are only present on certain system variants.
  2. Some of these warnings apply to accessories and may only be encountered if the particular accessory is fitted.

## A2.2 Alarms

The pump controller generates an alarm when a serious problem is encountered.

Depending on the reason for the alarm, the whole system or just the booster (if fitted) will shut down - refer to Section 4.4 and 4.5 for more information about alarms.

If the system has shut down due to an alarm, you must rectify the problem before you try to re-start the pump.

Once the problem that caused the alarm has been resolved, the alarm is cleared by the pump controller.

### A2.2.1 LED alarm indicators

Alarms are indicated on the LEDs on the front control panel and on the PDT if fitted.

The alarm LED on the front control panel illuminates continuously when an alarm is generated.

If a PDT is fitted, the alarm LED flashes to indicate a new alarm. Refer to Appendix A1.1.3 for more information on how alarms are indicated and how they can be acknowledged using the PDT.

Once all the alarms are cleared, the alarm LEDs extinguish. If the warning LED is illuminated then connect a PDT to determine the warning message and refer to Table A13 to identify the possible cause and corrective actions. If no PDT is available then you will have to systematically work through the actions listed in Table A13 until the alarm is cleared.

### A2.2.2 PDT alarms

If a PDT is fitted, each alarm triggers an alarm message to be displayed. Refer to Appendix A1.1.3 for more information on how alarms are handled by the PDT.

Table A14 lists the alarm messages that might be displayed on the PDT with possible causes and actions you should take.

Table A14 - Alarms

Warning Message on PDT	'Action' Message on PDT	Possible Cause	Action
Alarm 1.01 Stop Activated	-	- The emergency stop has been activated. - There is a fault with the EMS circuit or the EMS link plug has not been fitted or has come disconnected.	If the EMS button has been used on the pump, refer to <a href="#">Section 4.6</a> to re-set it. Otherwise check and reset the EMS circuit and re-start the pump.  <i>Note: The alarm message will remain on the display until you restart the pumping system.</i>
Alarm 1.01 Sys Config Fault	-	The pump system type has not been set properly.	Contact Edwards for a service engineer to configure the pump system type correctly or replace the pump controller electronics.
Alarm 184.10 Dry Pump Stopped	See manual	The dry pump speed is very low. The rotor might be locked.	Cycle the power to the pump and attempt to re-start. If this fails, contact Edwards.
Alarm 186.01 DP Inverter Trip	Code Axxxx Wyyyy aaaaaaaaaaaaaaaa	Dry Pump Inverter has raised an alarm and stopped the system.	Refer to <a href="#">A2.3</a> for more information.
Alarm 186.01 DP Not Running	See manual	Dry Pump Inverter will not start up when requested.	Check inverter fault history.
Alarm 186.13 No DP Inv Comms	See manual	The pump controller cannot communicate with the dry pump inverter during startup checks	Check the wiring between the pump controller and the dry pump inverter

### A2.3 Inverter warnings and alarms

The inverter used to drive the dry pump can also generate warnings and alarms if problems are encountered. Inverter warning and alarm codes are displayed by the PDT if fitted.

The alarm and warning codes are each reported as a 16-bit word encoded as 4 hexadecimal numbers. The codes are displayed as follows:

A1234 W5678

Where:

A signifies Alarm and

W signifies Warning

Digits 1 - 8 are reported as hexadecimal digits from 0 to F.

To determine the cause of a warning or alarm you must first decode each hexadecimal number. 0 indicates that there is no alert for that bit. Normally you will only see codes of 1, 2, 4 or 8 for each bit but if two or more events occur in the same bit then these will be added together.

For example:

5 = 1 + 4 so if code 5 is displayed it means that alerts 1 AND 4 are active

B = 1 + 2 + 8 so if code B is displayed it means that alerts 1, 2 AND 8 are active.

To decode inverter warning and alarm codes, refer to [Table A15](#) to convert the hexadecimal digits into alert combinations and then refer to [Table A16](#) and [A17](#)).

Table A15 - Hexadecimal to digital conversion

BIT set combinations		
Hexadecimal	Decimal	Combination
F	15	8+4+2+1
E	14	8+4+2
D	13	8+4+1
C	12	8+4
B	11	8+2+1
A	10	8+2
9	9	8+1
8	8	8
7	7	4+2+1
6	6	4+2
5	5	4+1
4	4	4
3	3	2 + 1
2	2	2
1	1	1

Table A16 - Inverter alarm codes

INVERTER ALARMS			
BIT set	Fault code combination	PDT reported fault name	Description
1	8	ACCELERATION_TO	If motor has not accelerated to a minimum speed of 10Hz within 60 secs then drive will try to restart 3 times before giving alarm
	4	OVERLOAD_TO	Alarm given when dry pump speed is below 7Hz for 3 minutes
	2	SC_MODE_INTERLOCK	Internal fault contact Edwards
	1	FLASH_DOWNLOAD_FAULT	Internal fault contact Edwards
2	8	POST_FAULT	Internal fault contact Edwards
	4	OSTEST_FAULT	Internal fault contact Edwards
	2	EEPROM_FAULT	Internal fault contact Edwards
	1	PWM_TRIP	Inverter output switched off, active when drive not running. Restart pump or cycle power to reset.
3	8	MISSING_PHASE_TIMEOUT	Indicates a missing input phase - check power connections to pump and fuses in supply. Warning should appear first and then dry pump trips after 10 minutes.
	4	EMS	EMS has been activated. Check EMS button and EMS plug in the back of pump.
	2	DESAT_FAULT	Internal fault contact Edwards
	1	UNDERT	Inverter is too cold. See warning register to determine source of problem.



Table A16 - Inverter alarm codes (continued)

INVERTER ALARMS			
BIT set	Fault code combination	PDT reported fault name	Description
4	8	OVERT	Motor/Drive system over temperature - refer to warning code to determine source. Check cooling.
	4	OVERI	Motor overcurrent
	2	OVERV	Inverter overvoltage
	1	Reserved	Reserved

Table A17 - Inverter warnings codes

Inverter warnings			
BIT	Fault code combination	Name	Description
5	8	Reserved	Reserved
	4	Reserved	Reserved
	2	LOWTW	Condensation warning, indicates that the inverter (water) temperature is lower than expected - possible causes include inverter water valve stuck open.
	1	HIGHTW	Indicates that the inverter temperature is higher than expected - possible causes include no or low cooling water flow, inverter water valve stuck closed or water pipe to inverter blocked.
6	8	HIGHTC	Controller temperature above upper limit / Controller temperature sensor open circuit - check water supply
	4	HIGHTS	Inverter heat-sink temperature above upper limit / Inverter heat-sink temperature sensor open circuit - check water supply
	2	HIGHTM	Motor temperature above upper limit / Motor temperature sensor open circuit - check water supply
	1	MISSING_PHASE	The loss of one of the three input phases has been detected - check mains supply to drive or blown fuses
7	8	UTCREG	Upper controller temperature regulator active - current limit reduced - check cooling
	4	UTSREG	Upper heat sink temperature regulator active - current limit reduced - check cooling
	2	Reserved	Reserved
	1	LVREG	Lower voltage regulator active - check mains voltage
8	8	LOWVCC	Internal power supply fault - contact Edwards
	4	LOWTC	Low controller temperature - contact Edwards
	2	LOWTS	Low heatsink temperature - contact Edwards
	1	CAN LOSS	Reserved

Example:

PDT shows the following:  
A0108 W0200

This translates to:

alarm 1 in bit 2 - PWM\_TRIP

alarm 8 in bit 4 - OVERT

warning 2 in bit 6 - HIGHTM.

This means the motor overheated and switched the output off.

## A2.4 Other

### A2.4.1 Pump controller communications

The pump controller contains two processors that perform separate functions. Under normal operation the two processors communicate with each other internally but under fault conditions it is possible that the two processors will stop communicating. The behaviour of the system will depend on its mode of operation prior to the communication failure. There may be no change in operation initially.

To minimise impact on process, the system will continue to run normally if it was already running when the communication failure occurred. The gas valves and Gate valves remain in the state that they were in prior to the communication failure and outputs to the MicroTIM are unaffected. It is important to note, however, that control might be released from the device that was 'in control' (for example PDT) and that stop requests will be ignored from all devices apart from the front panel controls.

To stop a system that has suffered a communication failure either use the EMS or use the front panel controls to 'take control' of the system and then stop it. In this situation, the warning LED on the pump will flash, the alarm LED will illuminate and the inlet Gate valve will close. The pump will stop immediately without any gas purges. Any requests to start the pump will be rejected until the fault has been rectified.